

Installation Manual

Neo[®] Rooflight

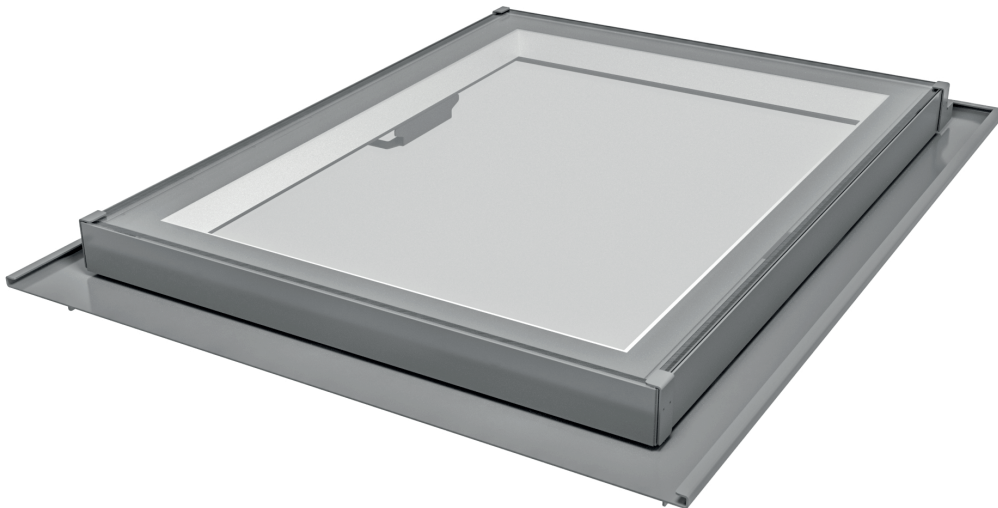

A roof window range suitable for pitched roofs between 20° and 60°.

Details for use with flashing kit.

SECTION 1 - How to use this manual

> Welcome

> General

WELCOME

Thank you for choosing the Neo® Rooflight. We are sure that the Neo® Rooflight will provide a high-quality finishing touch to your project. This guide is intended to assist building contractors and homeowners in receiving, handling and installing the Neo® Rooflight. Please take the time to read and carefully follow these instructions. Before you start your installation, please refer to the 'IMPORTANT INFORMATION' section at the back of this installation guide.

GENERAL

Please note: the minimum roof angle at which the Neo® Rooflight can be installed is 20 degrees.

Please note: the maximum roof angle at which the Neo® Rooflight can be installed is 60 degrees.

Please note: the following installation details pertain to COLD ROOF construction and CLAY tile type installed 'on the rafters', with use of the flashing kit. Some installation details may vary depending on the roof construction and tile type being used. Always view this manual in conjunction with the cross sectional installation details relevant to your project. See Section 8 (Pages 25,26 &27) 'Suggested installation details' towards the back of this manual.

In order to install the Neo® Rooflight you will need to know:

1. The Neo® Rooflight model to be installed.
2. The type of roof construction to be used, e.g. warm roof or cold roof.
3. The type of roof tile to be used, e.g. clay tiles, slate, interlocking tile, pantile, zinc or lead sheet, etc.
4. Whether you wish to install 'on the rafter' or 'between the rafter'

TEXT- Highlighted in **BOLD** indicates a point of special importance.



PPE NOTE

The images in this manual are intended to aid installation and where required the installer must use suitable PPE (which may not be shown) and abide by the applicable Health & Safety requirements. It is assumed that suitable method statements and risk assessments will be undertaken prior to installation.



NOTE: PRESSURISED GAS SPRINGS

Please be aware that some of the Neo® Rooflight's utilise gas springs to aid opening the roof window, depending on the model. If the connection at the cill is disengaged then the casement may gradually start to open.

▼ CONTENTS	▼ PAGE
SECTION 1 - How to use this manual	2
SECTION 2 - Before you get started	4
SECTION 3 - Prior to installation	6
SECTION 4 - Preparing the structural opening	7
SECTION 5 - Preparing the roof	9
SECTION 6 - Installing the roof window	13
SECTION 7 - Finishing the interior	22
SECTION 8 - Suggested installation details	25
SECTION 9 - Important Information	28

SECTION 2 - Before you get started

> Contents of the box

CONTENTS OF THE BOX

> Neo® Rooflight

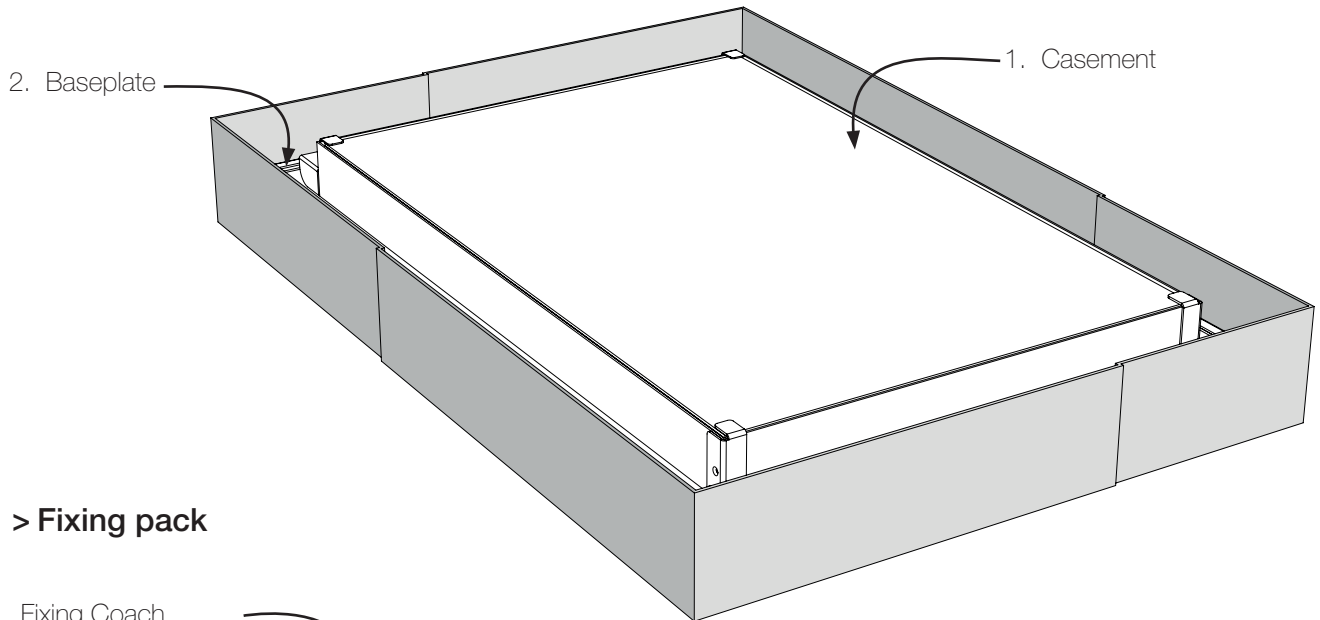

> Fixing pack

4. Fixing Coach Screw

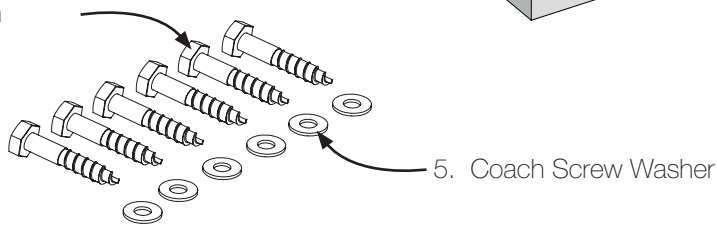

> Flashing Kit- Purchased separately

8. 1x cill lead flashing
9. 1x head lead replacement flashing

11. 1x jamb flashing off-cut

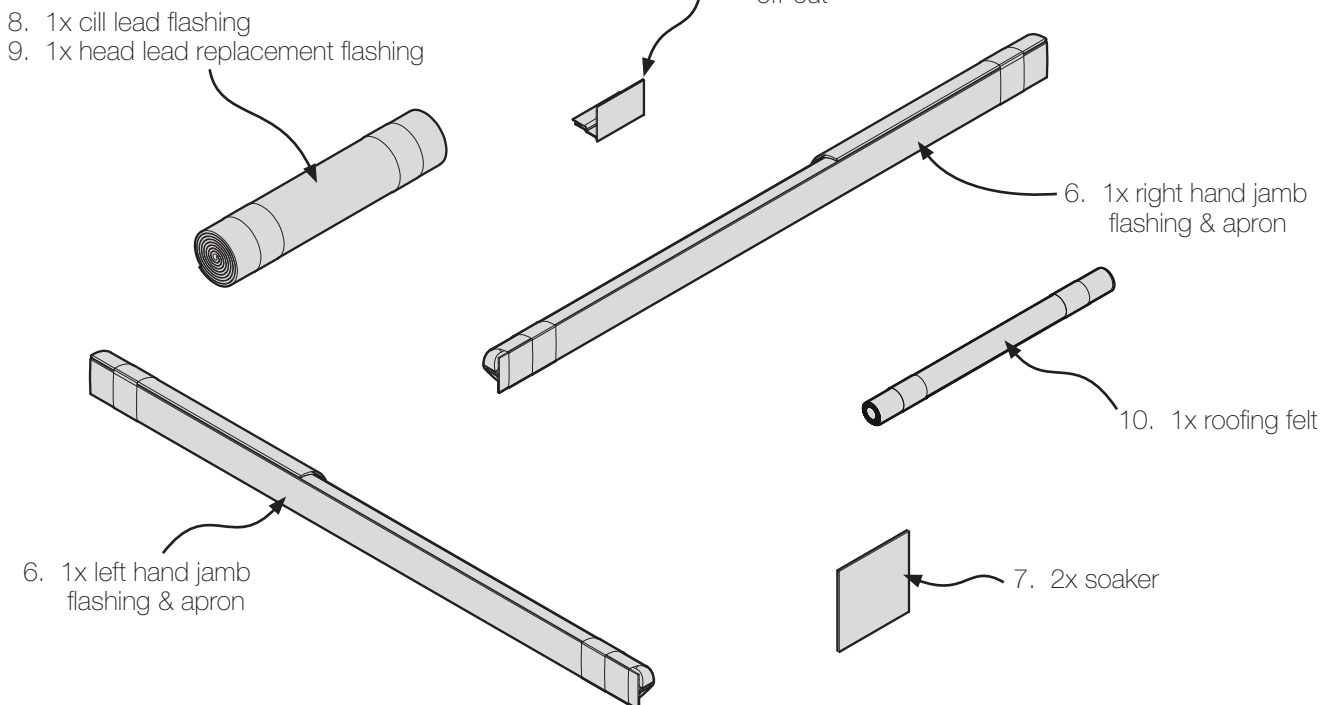

SECTION 2 - Before you get started

> Parts List

PARTS LIST

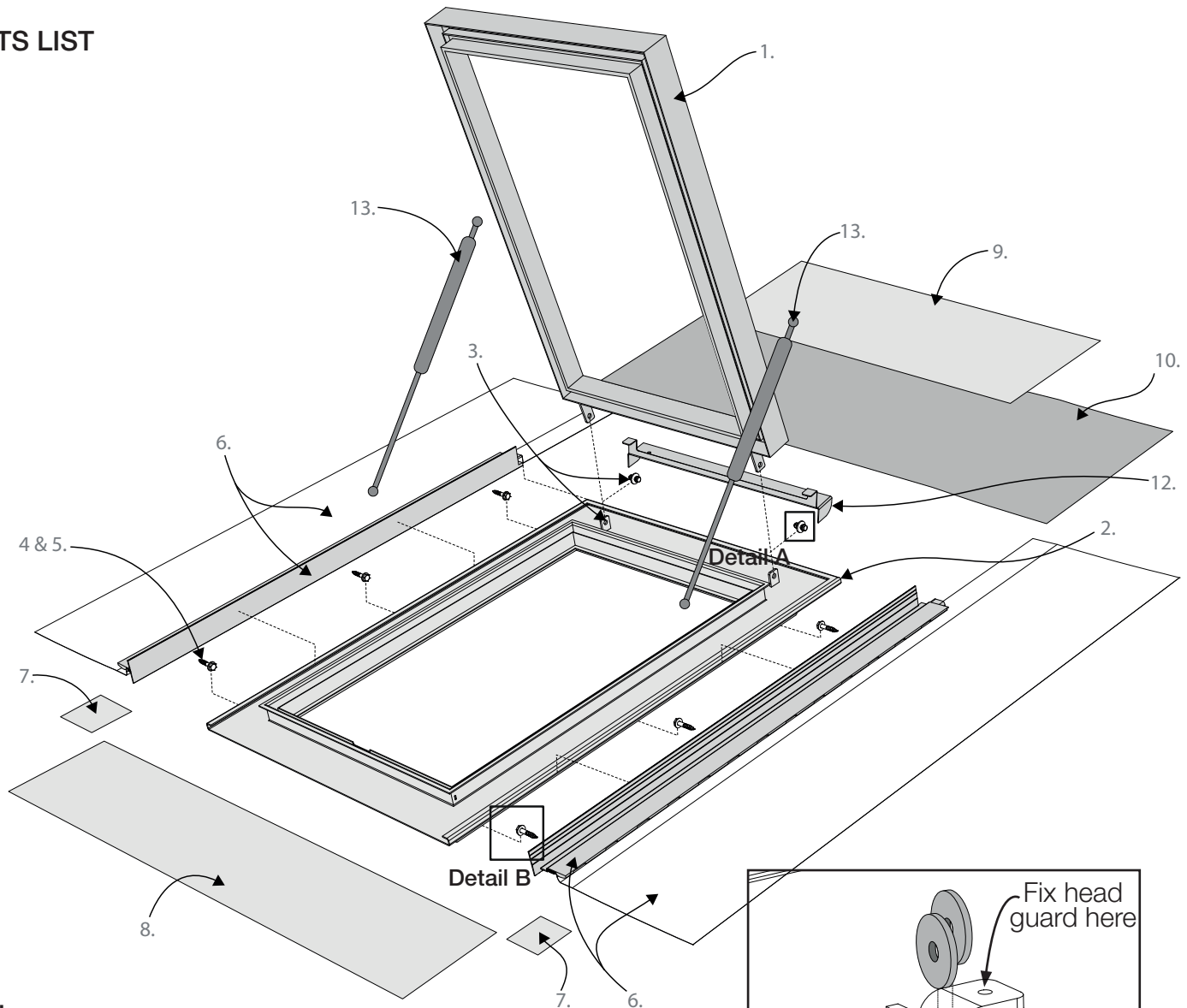

Part Number	Description	Quantity
1	Casement	1
2	Baseplate	1
3	Hinge & fixings.....	Various
4	Fixing coach screw	Various
5	Coach screw washer	Various
6	Jamb flashing	2
	& Jamb flashing apron	2
7	Soaker	2
8	Cill lead flashing	1
9	Head lead replacement flashing ...	1
10	Roofing felt	1
11	Jamb flashing off-cut.....	1
12	Head guard	1
13	Gas spring	2

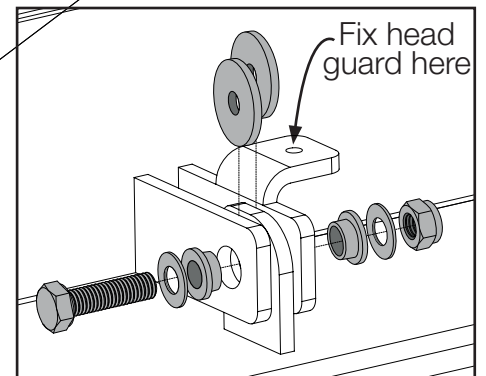

Detail A

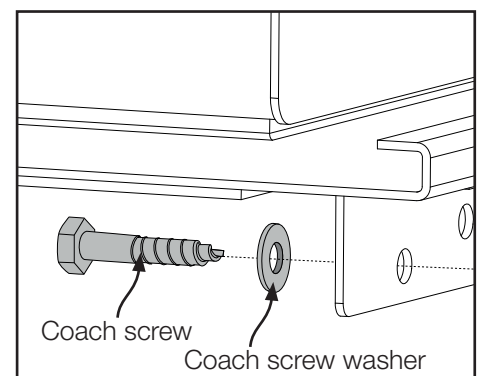

Detail B

NOTE: Please refer to separate manuals for installation of ironmongery/motors/fixing bracket/blinds

SECTION 3 - Prior to installation

> Receiving the roof window

> Transport & storage

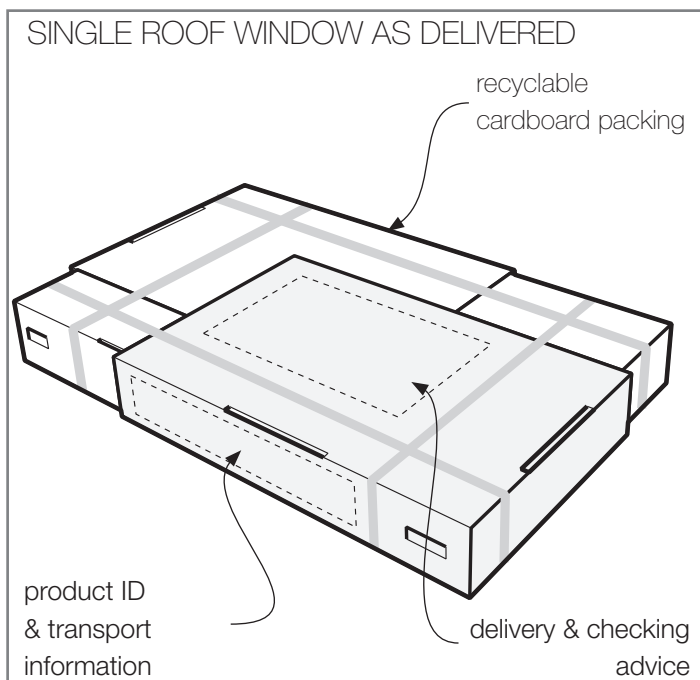

RECEIVING THE ROOF WINDOW

We recommend that the roof window packaging is temporarily opened to allow inspection of the goods for damage. Follow the instructions on the delivery checking and advice label.

- ▶ Once the roof window has been checked, repackage it in the original packaging for safe storage until the roof window is to be installed.

TRANSPORT & STORAGE

- ▶ Keep the roof window in its original packaging and store off the ground in a secure covered dry place until it is required for installation.

- ▶ When transporting the roof window in its box, carry the box by lifting it from the underside rather than lifting by its strapping.



Only carry the box if the banding is attached in its original condition. Do not carry by the box if the nylon banding has been cut or appears in any way damaged.

- ▶ Stack multiple units carefully and only as many units high as is set out on the transport information label on the box.
- ▶ Only remove the roof window from its packaging when it is required for installation.
- ▶ Once unpacked carry the roof window by lifting it from the underside of the baseplate.
- ▶ Mark the original box with the window number/location and keep all accessories and linings in the original box until they are required. When the installation is complete and all accessories/linings are used, recycle all of the packaging materials.

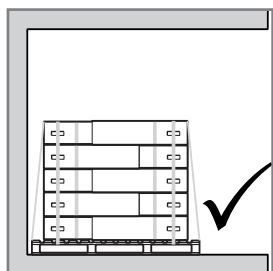

Store in a covered dry secure area

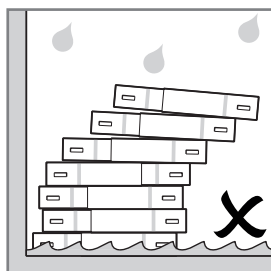

Do not stack too high or allow to get wet

SECTION 4 - Preparing the structural opening

> Type of roof

Before you can derive the structural framing dimensions you will need to understand which of the following options apply to your project:

ON THE RAFTER OR BETWEEN THE RAFTER

The type of tiles used affects how the roof window is installed. One of the following options will be used:

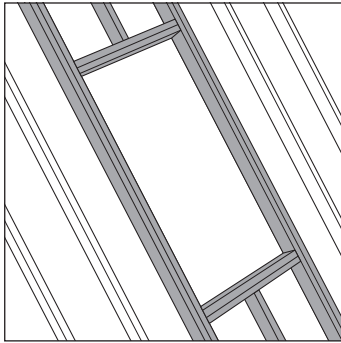

On the Rafter (Standard Installation):

This installation (as the name suggests) installs the roof window with it sitting on top of the rafters. For the majority of profiled tiles (Clay, Pantile etc) the roof window remains flush to the top of the tiles and will not project above the finished roof line. For thinner tile types (Slate) the roof window will not be flush and will project above the finished roof line. If a flush detail is required for thin tile types then a 'between the rafter' (commonly referred to as Flush Slate) installation is required.

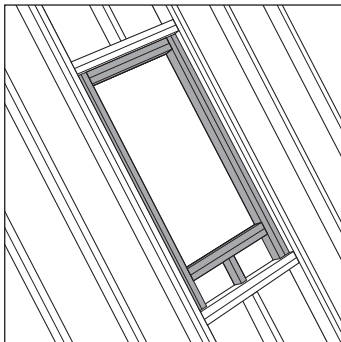

Between the rafter (Flush Slate Installation):

When tile types are thinner and a standard 'on the rafter' installation would result in a non-flush installation; a 'between the rafter' installation can be used. The roof window is sunk in between the rafters to a depth equal to the height that it would protrude above the finished roof line if a standard installation was used, nominally to a sunk depth of 20mm (Installers are advised to check this dimension prior to installation). Due to the roof window being sunk below the top of the rafters, the associated structural framing sizes increase. Likewise, dependent upon the pitch of the roof, the run-off required at the cill tilting fillet may vary. Nominally quoted framing sizes use the lowest installation pitch and calculate for worst case scenario.

WARM OR COLD ROOF CONSTRUCTION TYPE

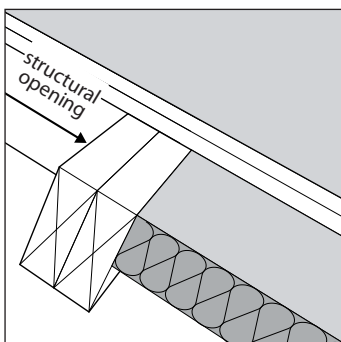

Cold roof

In a cold roof construction, the insulation layer is placed horizontally, directly above the ceiling of the upper story of the habitable section of the building, usually positioned between the joists in the loft space.

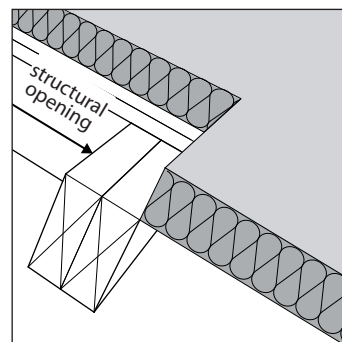

Warm roof

In a warm roof construction, the insulation is positioned directly under the external waterproofing (e.g. tiles or slates), following the rafter line.

INSTALLATION HEIGHT

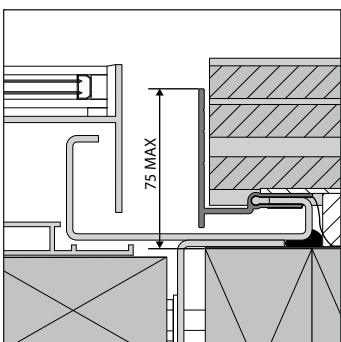

The maximum height that can be used with the flashing kit is 75mm for all tile types. This is measured from the top of the soaker extrusion (part 6) to the top of the structural support (as shown). If your tiles are thicker than this then we recommend the use of lead soakers or mortar bed at the jambs.



NOTE: The flashing kit is only suitable for 'on the rafter' installation.

SECTION 4 - Preparing the structural opening

> Type of installation

TYPE OF INSTALLATION

To derive the structural framing dimensions for the Neo® Rooflight. You will need to have the following information to hand:

- ▶ The Neo® Rooflight model reference number to be installed.
- ▶ The type of roof construction to be used e.g. cold or warm.

Follow the appropriate information pathway to derive the structural framing dimensions below.

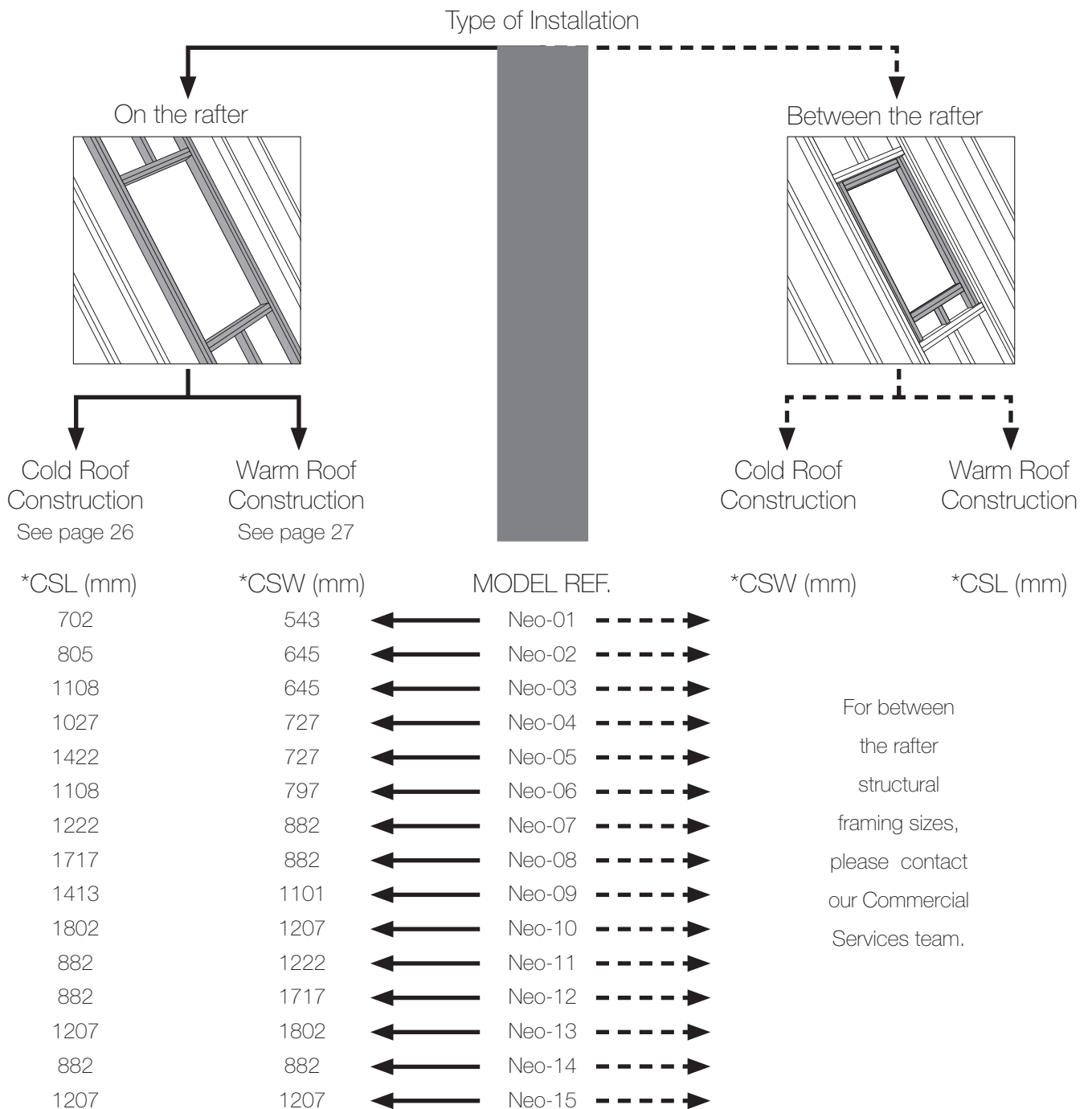

* CSW = Clear Structural Width,
 CSL = Clear Structural Length
 (for 'on the rafter' installation only)

SECTION 5 - Preparing the roof

> Forming the structural opening

FORMING THE STRUCTURAL OPENING

The opening is formed using additional structural members which re-route the structural loads from the roof above, around the structural opening.



NOTE: All structural member sizing and fixings around the structural opening are to be as detailed by the project architect/structural engineer. Our drawings are indicative only.

Neo® Rooflight- in a new roof

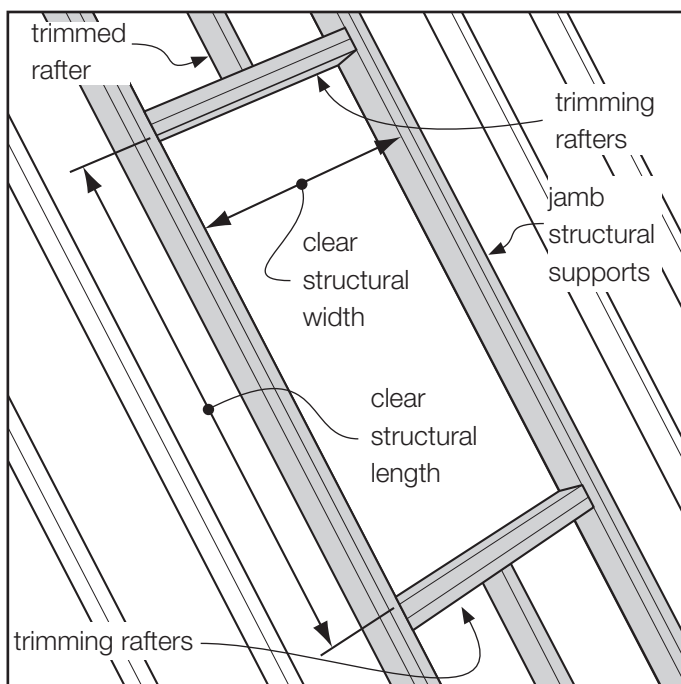

In a new roof the structural members can be designed to reduce the necessity for cutting and trimming.

NOTE: The rafters and trimmers are doubled up in the image

Neo® Rooflight - in an existing roof

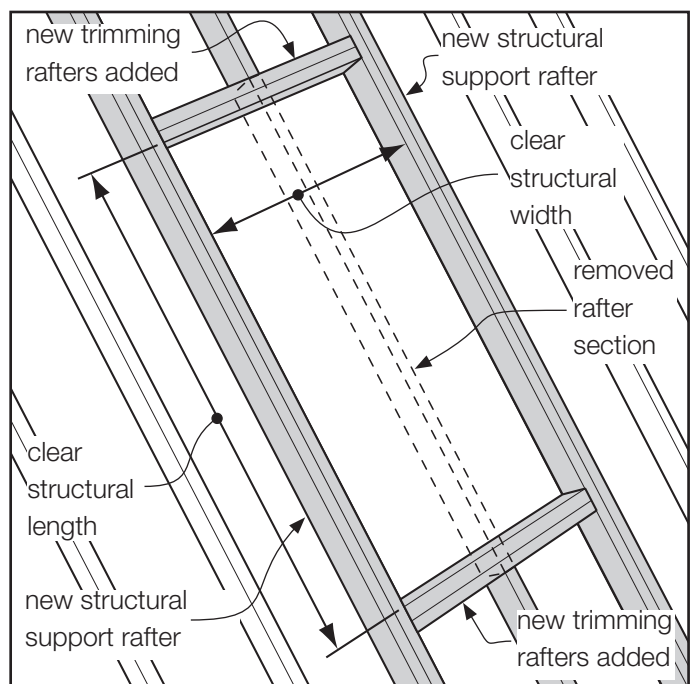

In an existing roof the structural opening may require additional structural members to be inserted and/or existing members cut and re-supported in order to facilitate installation in the location required.

NOTE: The rafters and trimmers are doubled up in the image

SECTION 5 - Preparing the roof

- > Prepared opening
- > Trim & finish the roofing membrane

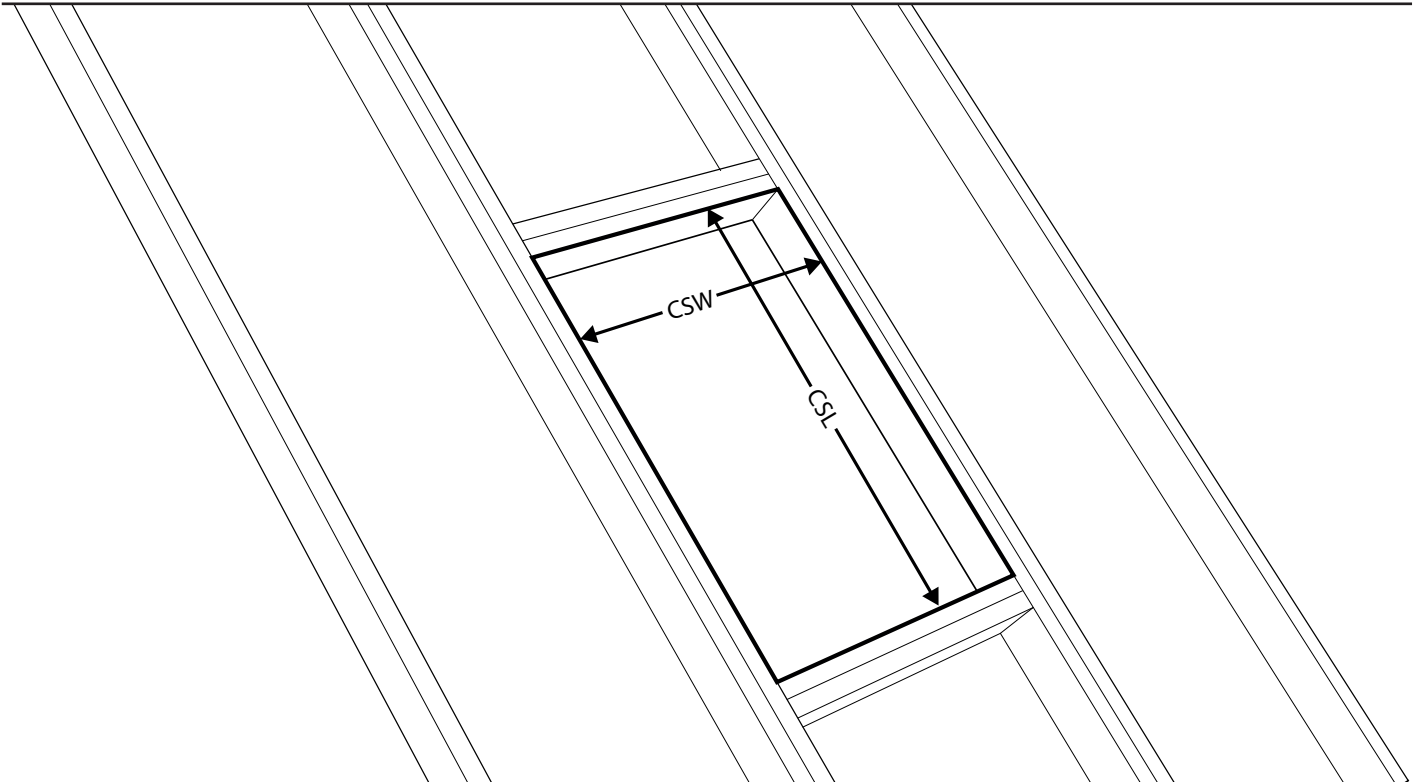

▲ Prepared Opening

Trim the opening within the roof to the correct size required for the model of the roof window being installed. For instructions see:
Type of Installation (Pg 8)

Fold and trim the roofing membrane around the structural opening as shown.

▼ Trim & finish the roofing membrane

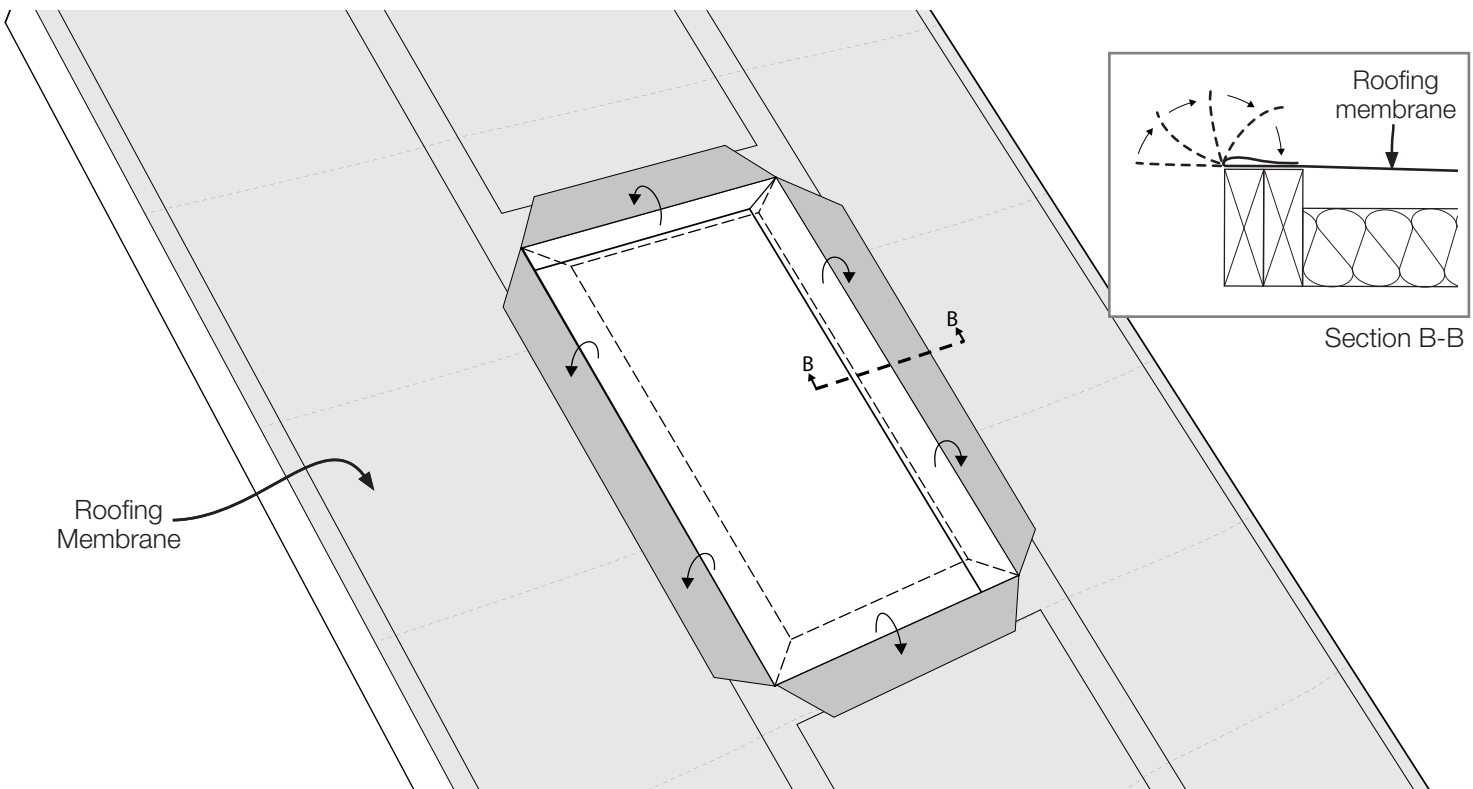

SECTION 5 - Preparing the roof

> Cill tilting fillet

> Battening up to the cill

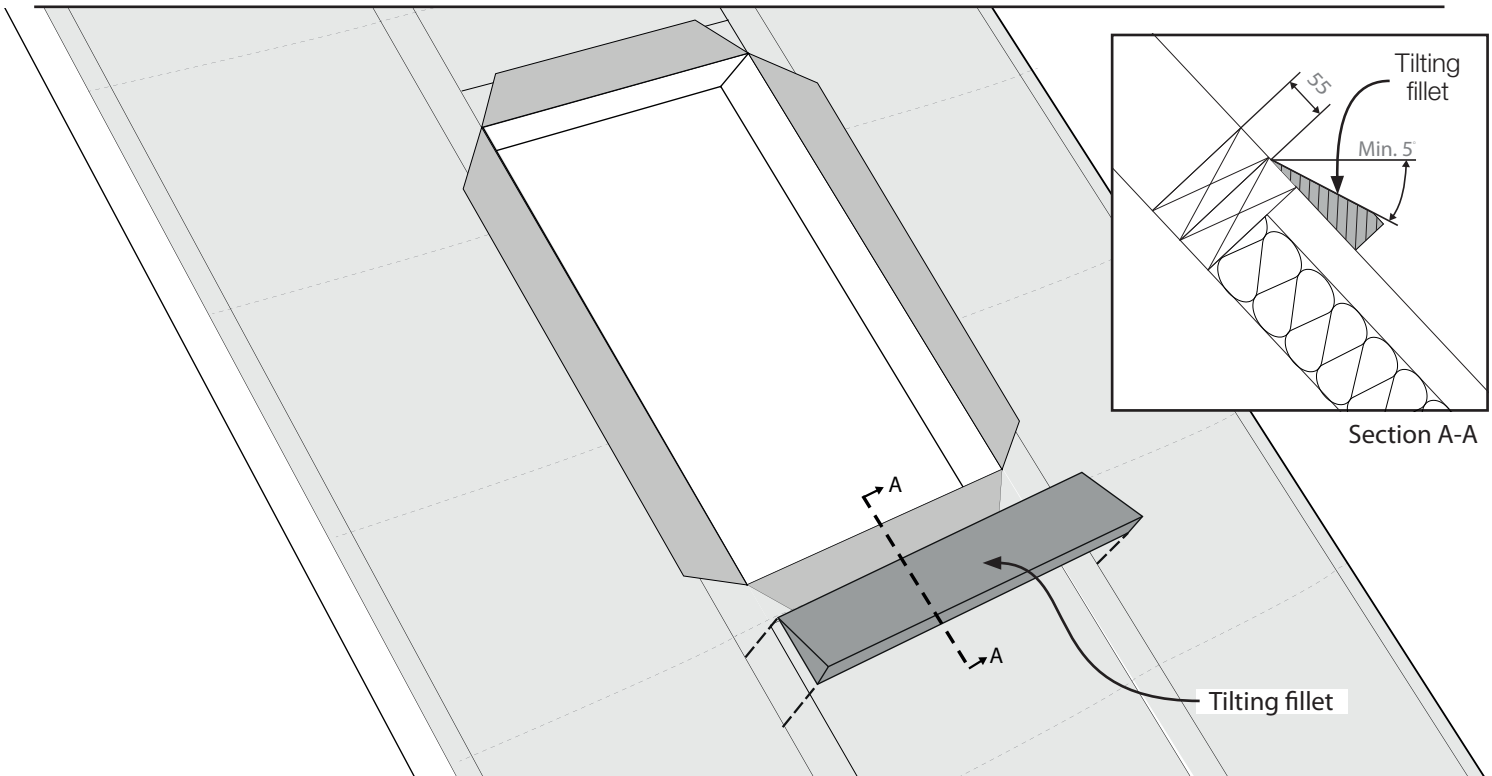

▲ Installing a cill tilting fillet

Install a cill tilting fillet as shown (we recommend hardwood or treated softwood). Fix the cill tilting fillet to the rafters.

It is recommended that the roof is battened up to the cill of the opening at this stage. Batten spacing is determined by the roof covering being used. Adjust the battening and tiling to course and fit around the structural opening.

▼ Battening up to the cill

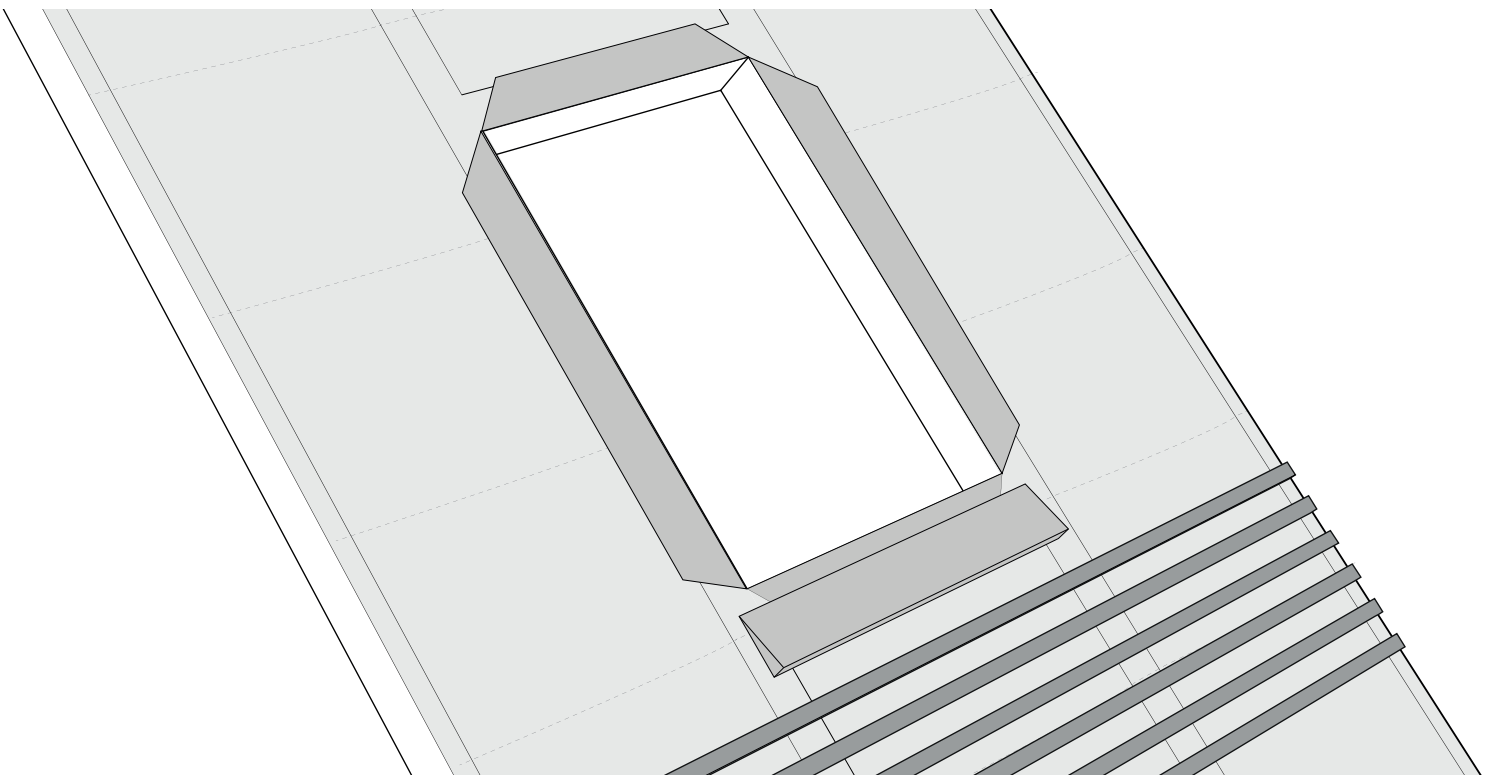

SECTION 5 - Preparing the roof

- > Cill lead flashing
- > Cill silicone fillet

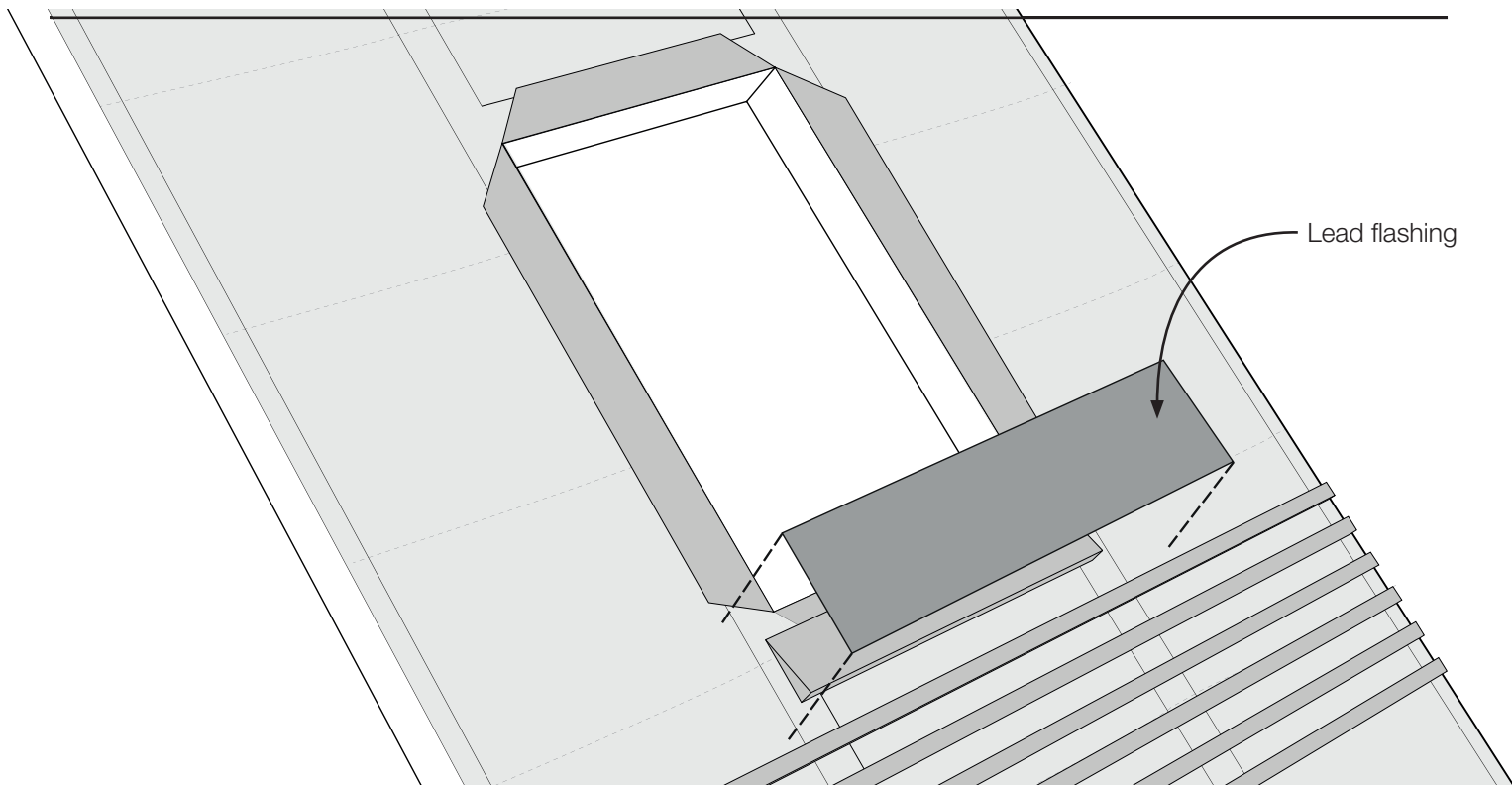

▲ Cill lead Flashing

Install cill lead flashing (Part 8) to the cill of the opening as shown. Side lap to be minimum 150mm. Length of flashing to be sufficient to give the tile-recommended headlap.

Lay a continuous thick bead of low-modulus neutral cure silicone along the flashing for the cill of the roof window.

▼ Cill silicone fillet

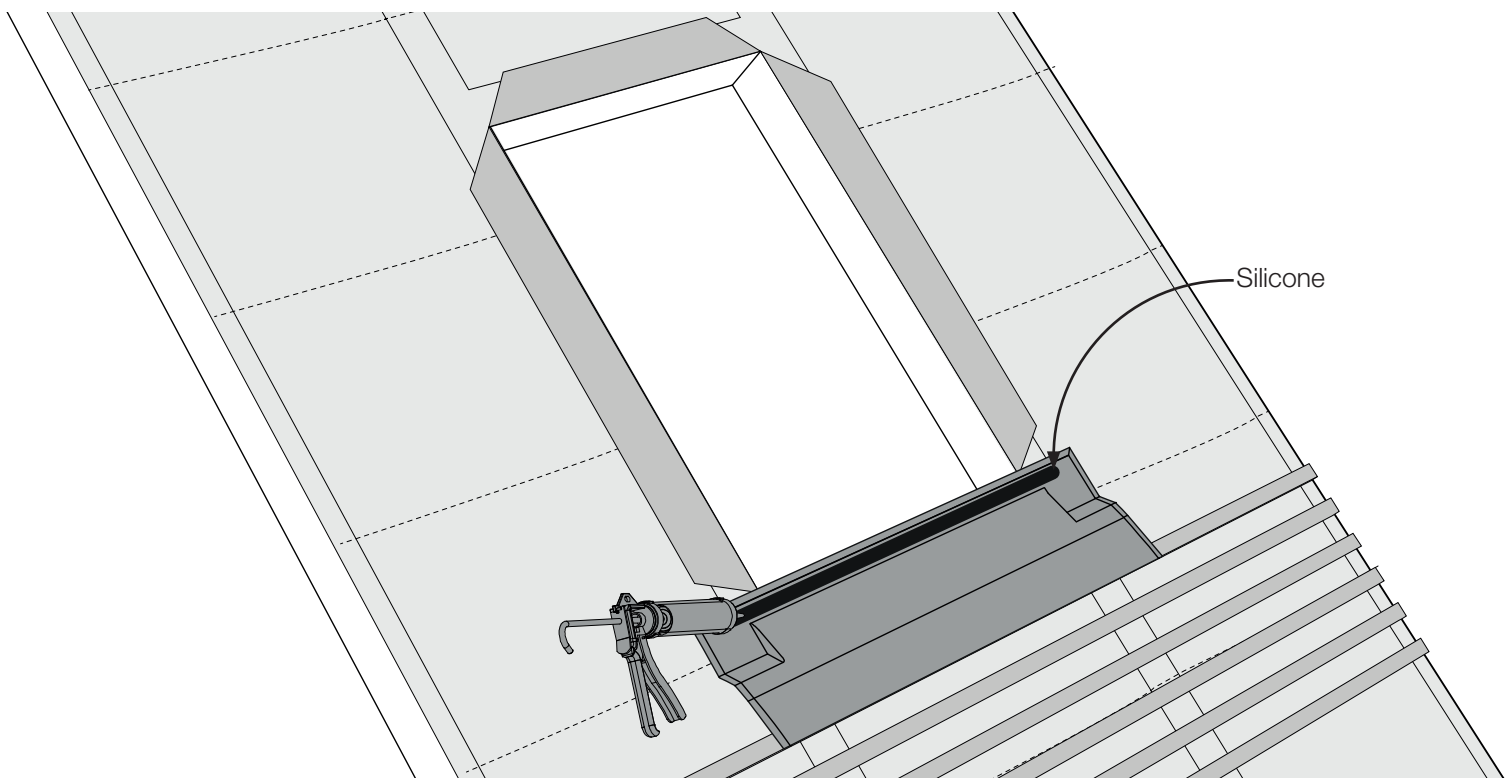

SECTION 6- Installing the roof window

> Installing the roof window

> Fix / level

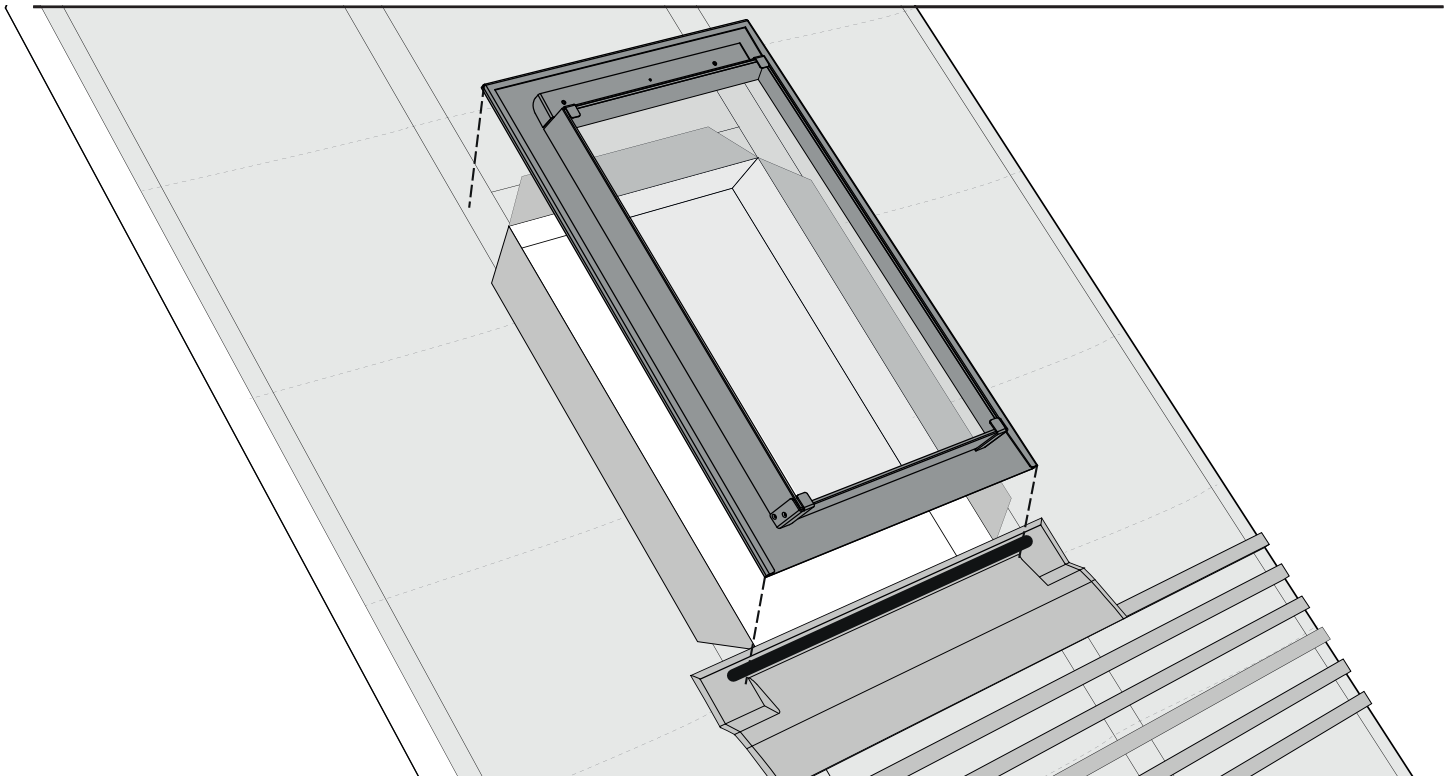

▲ Installing the roof window

Lift the roof window into the opening (Part 1 & 2).

Locate all of the fixing points at the perimeter of the roof window. Drill pilot holes and fix the coach screws (Part 4) with a large flat washer (Part 5) into the structural bearers. **OVER TIGHTENING OF THE COACH SCREWS CAN CAUSE DAMAGE TO THE ROOF WINDOW FRAME, IT MAY BE NECESSARY TO PACK BEHIND THE FIXING RAIL.** Ensure an even number of coach screws are used across each jamb.

▼ Fix / level

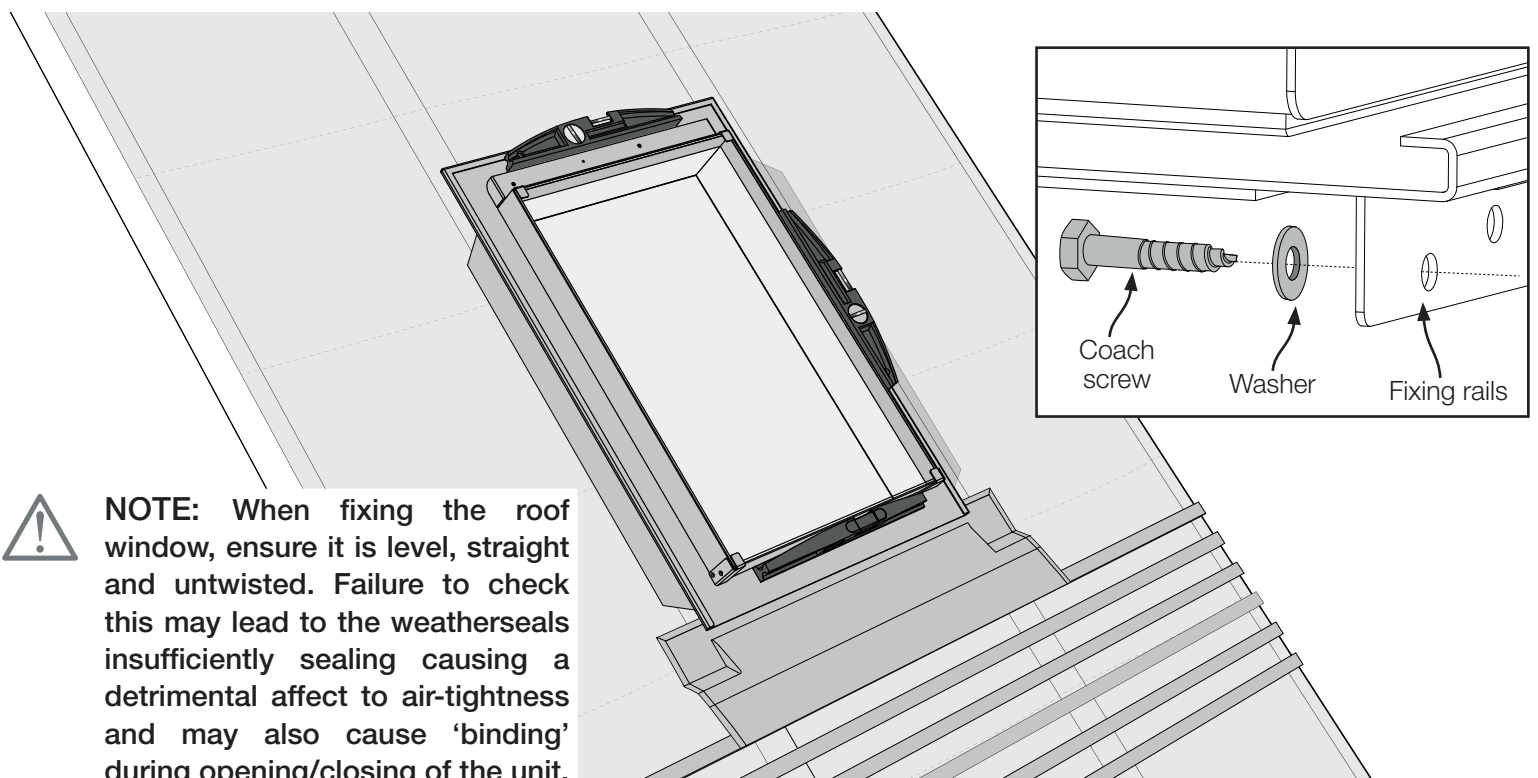

NOTE: When fixing the roof window, ensure it is level, straight and untwisted. Failure to check this may lead to the weatherseals insufficiently sealing causing a detrimental affect to air-tightness and may also cause 'binding' during opening/closing of the unit.

SECTION 6 - Installing the roof window

- > Perimeter silicone fillet
- > Jamb flashing trim height

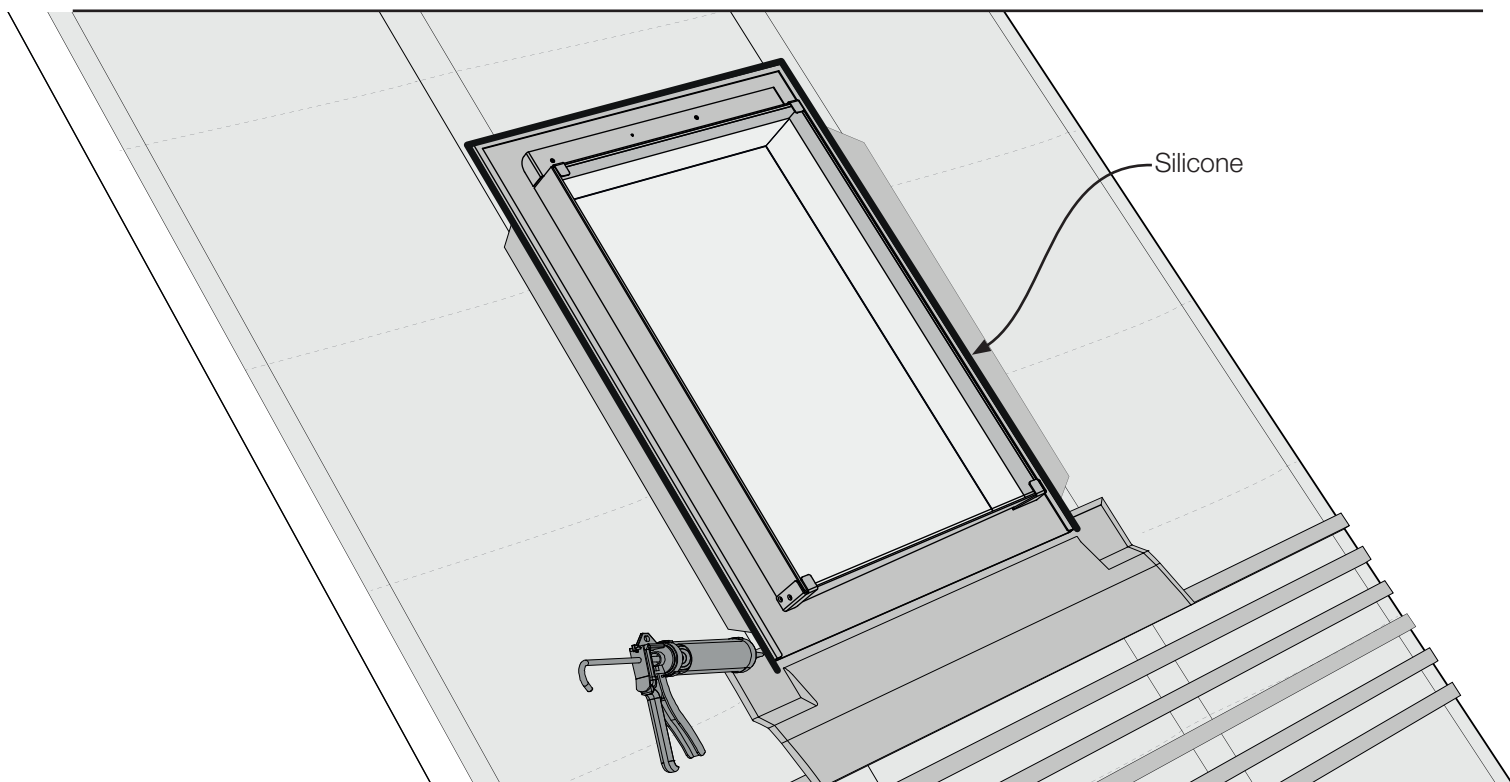

▲ Perimeter silicone fillet

Install a thick continuous fillet of low-modulus neutral cure silicone to full length and width of the jambs and head of the roof window perimeter as shown.

Tack four rows of battens up one jamb- do not nail home the ends of the battens next to the roof window.

▼ Jamb flashing trim height

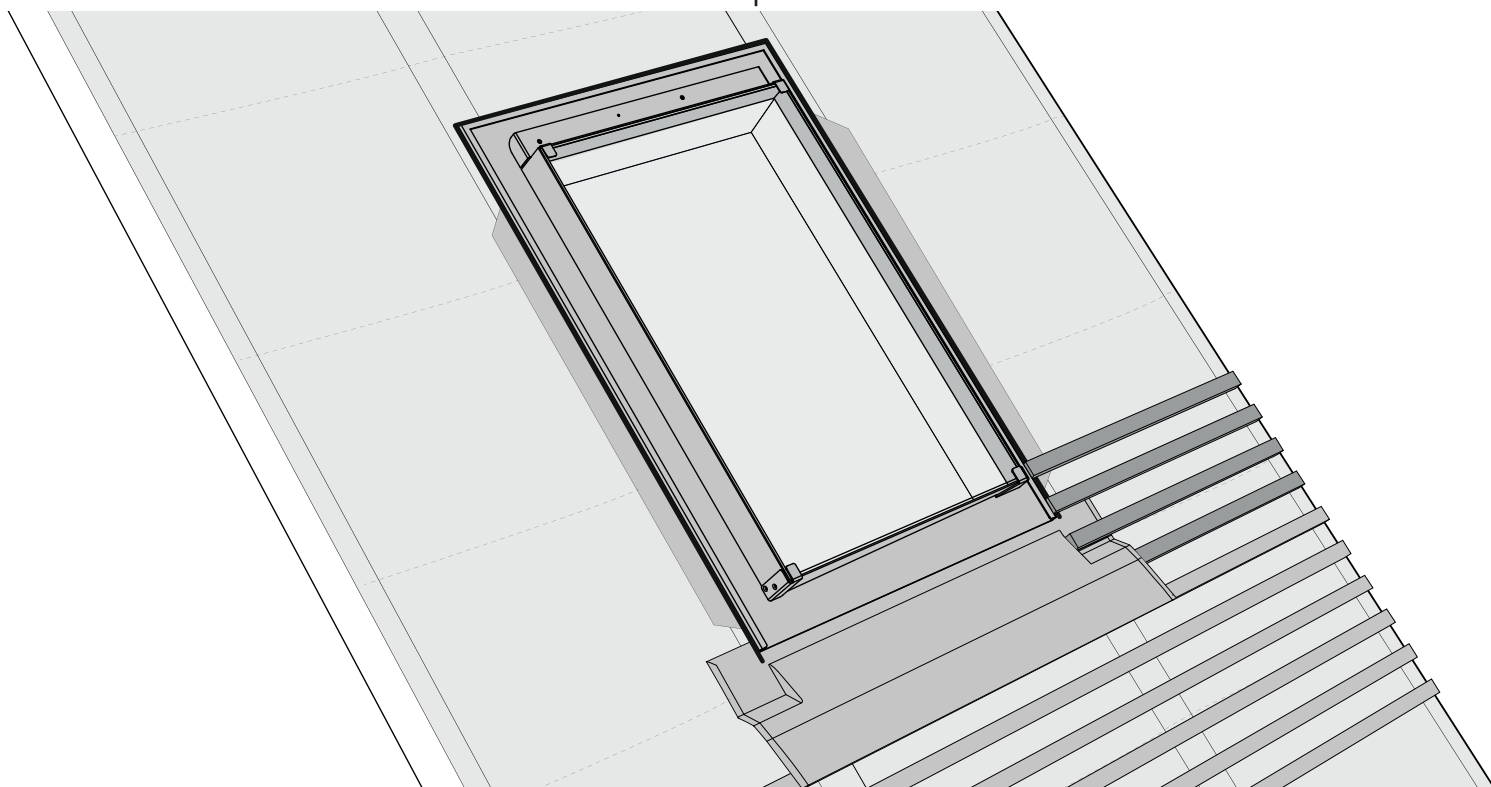

SECTION 6 - Installing the roof window

> Jamb flashing trim height

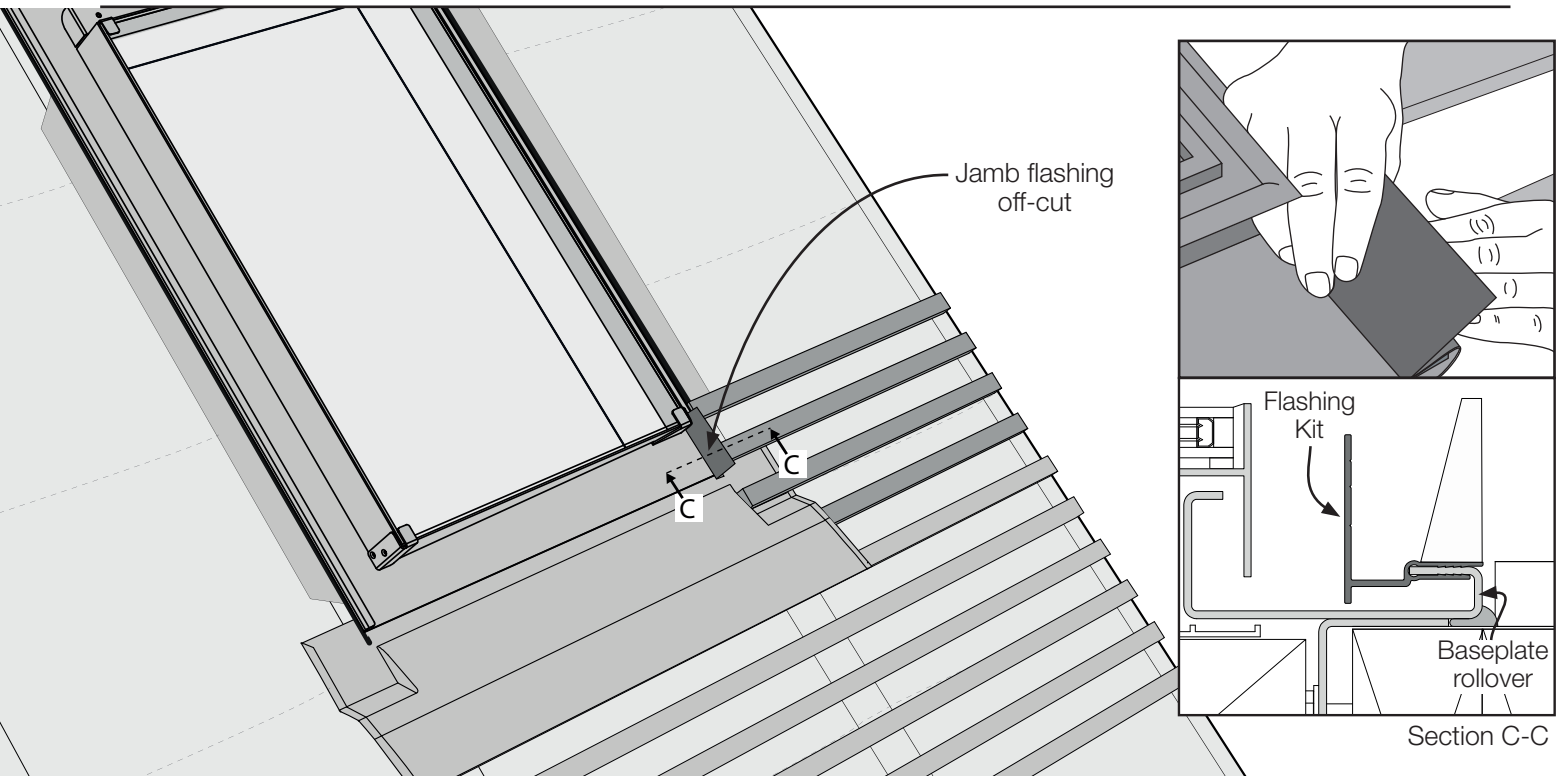

▲ Jamb flashing trim height

Clip the jamb flashing off-cut (Part 11) onto the baseplate rolover and align with the bottom edge of the baseplate (Part 2).

Dry tile four courses of tiles at the cill. Use the jamb flashing off-cut (Part 11) to determine whether or not it is required to trim down the jamb flashing (Part 6). If the top edge of the off-cut sits above the general line of the roof finish, trimming is required.

▼ Jamb flashing trim height

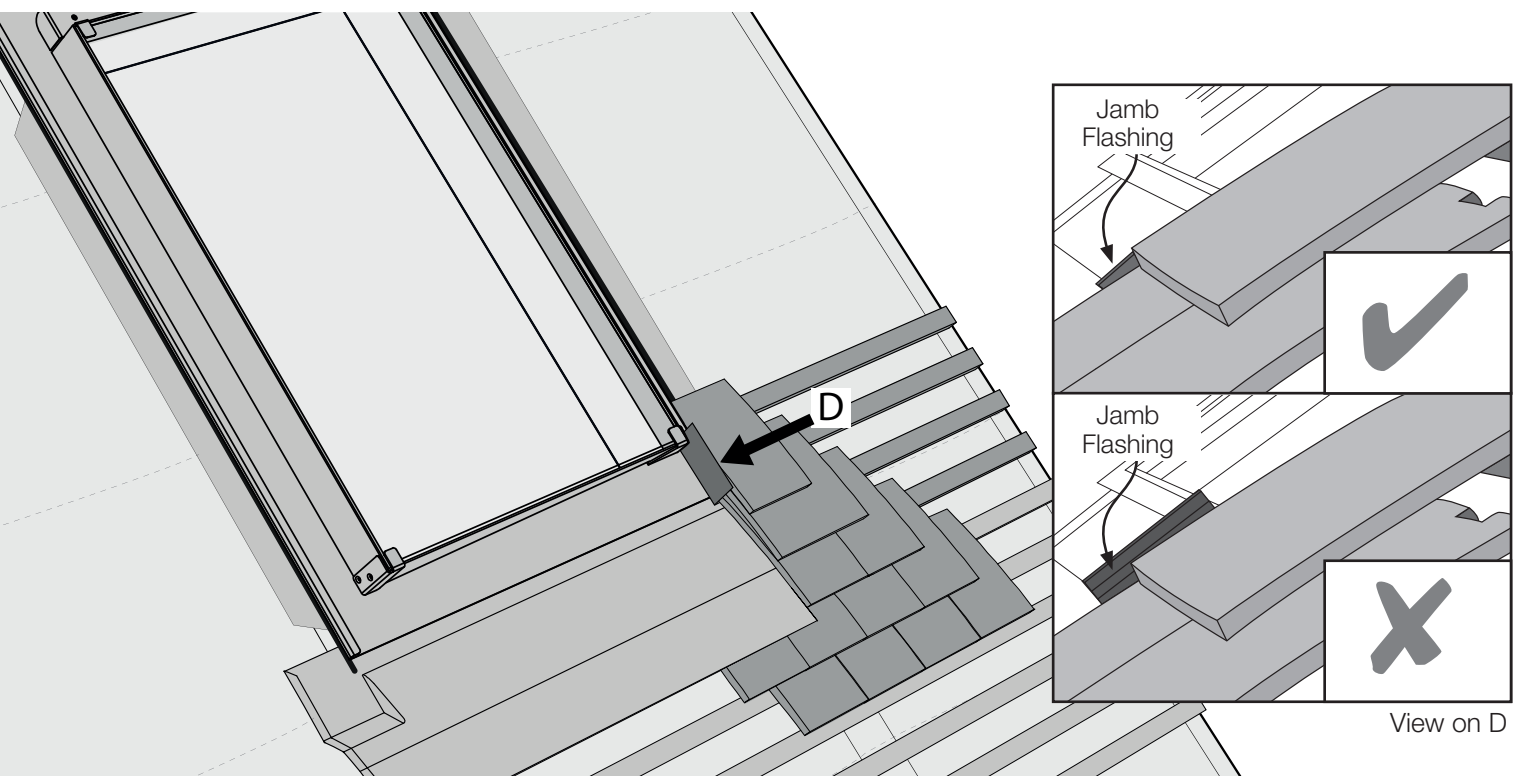

View on D

SECTION 6 - Installing the roof window

> Trimming the jamb flashing extrusion

> Installing the jamb flashing

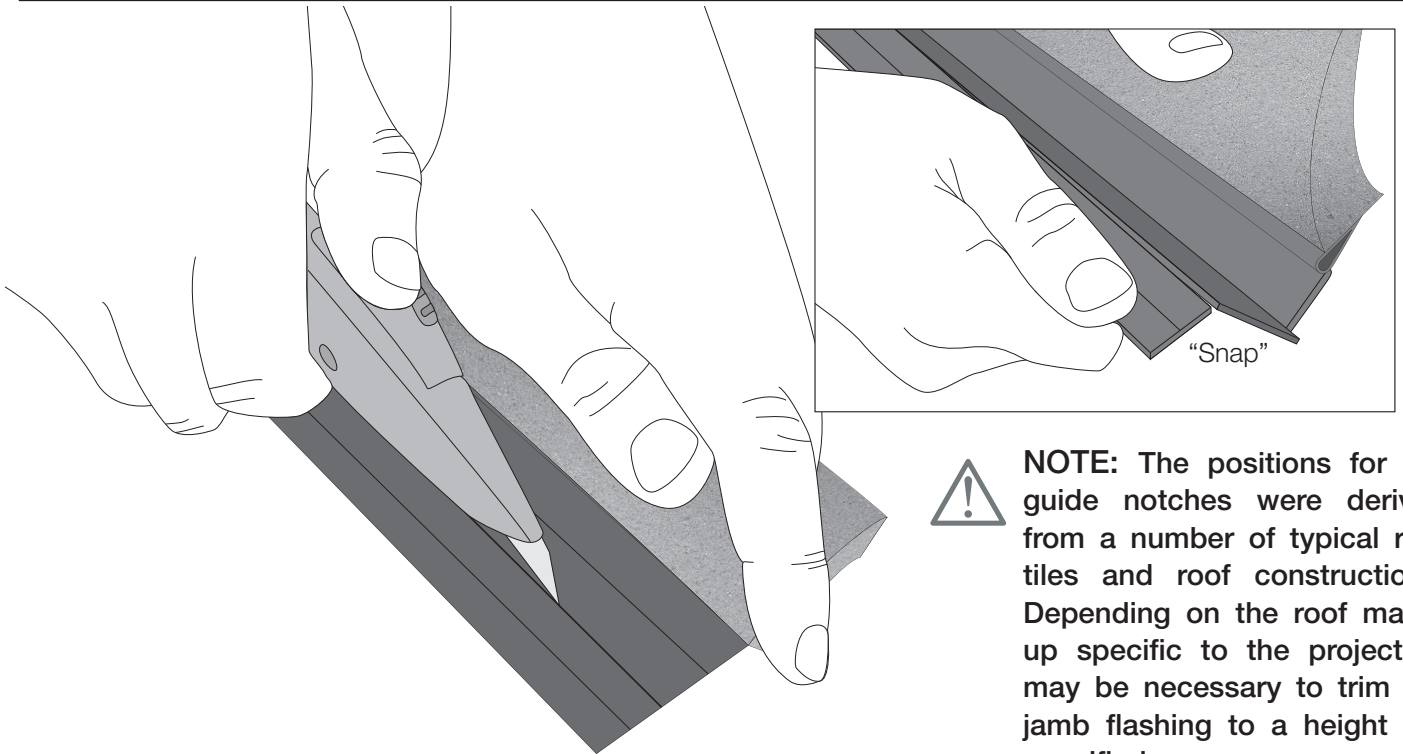

NOTE: The positions for the guide notches were derived from a number of typical roof tiles and roof constructions. Depending on the roof make-up specific to the project. It may be necessary to trim the jamb flashing to a height not specified.

▲ Trimming the jamb flashing extrusion

Lay the jamb flashing (Part 6) down on a clean and dry surface. Fold back the foam and use a sharp knife to firmly score along the entire length of the extrusion several times. Then break off the excess extrusion.

Orientate one of the jamb flashings (Part 6) and clip onto the baseplate (Part 2) rollover- the excess felt on the jamb flashing should be towards the head of the roof window. Do the same on the opposite side. Ensure the felt attached to the jamb flashing is placed over the general roofing membrane.

▼ Installing the jamb flashing



NOTE: If the excess felt attached to the jamb flashing (part 6) meets the next lap in the general roofing membrane, ensure it is tucked into this lap.

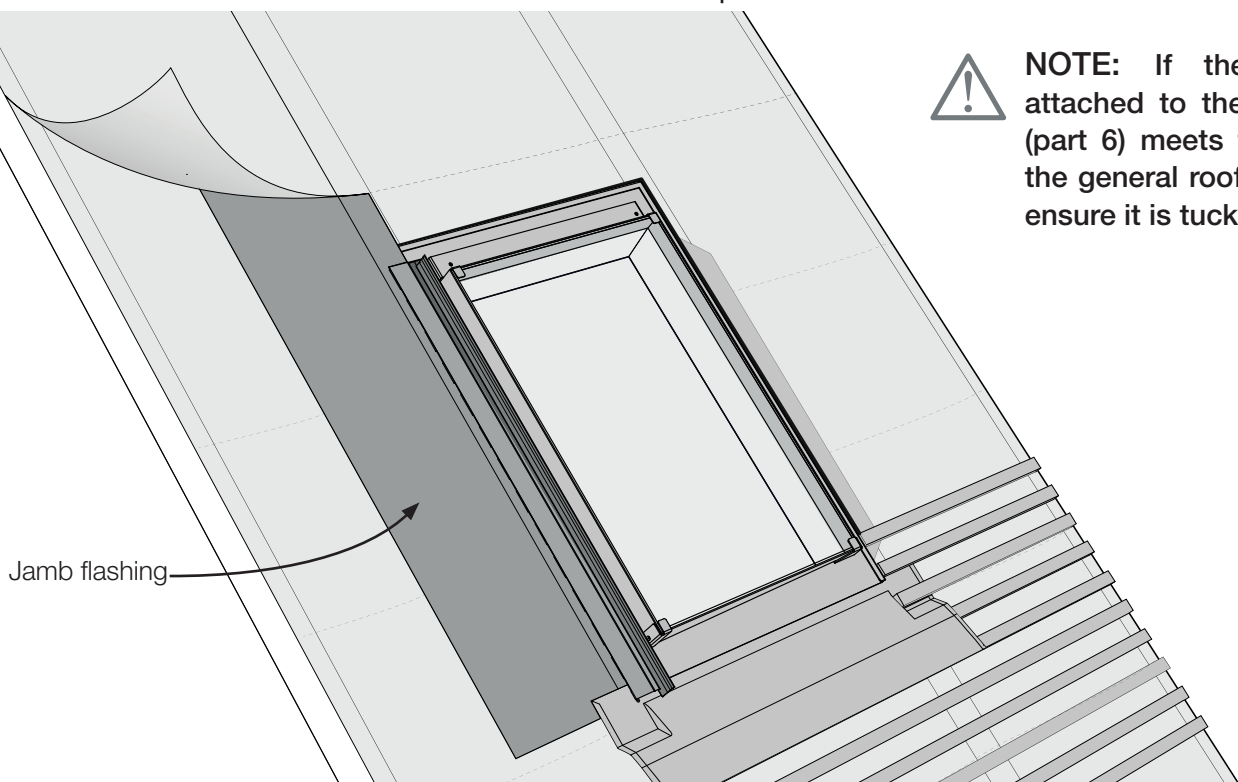

SECTION 6 - Installing the roof window

- > Battening up the jambs
- > Installing the head tilting fillet

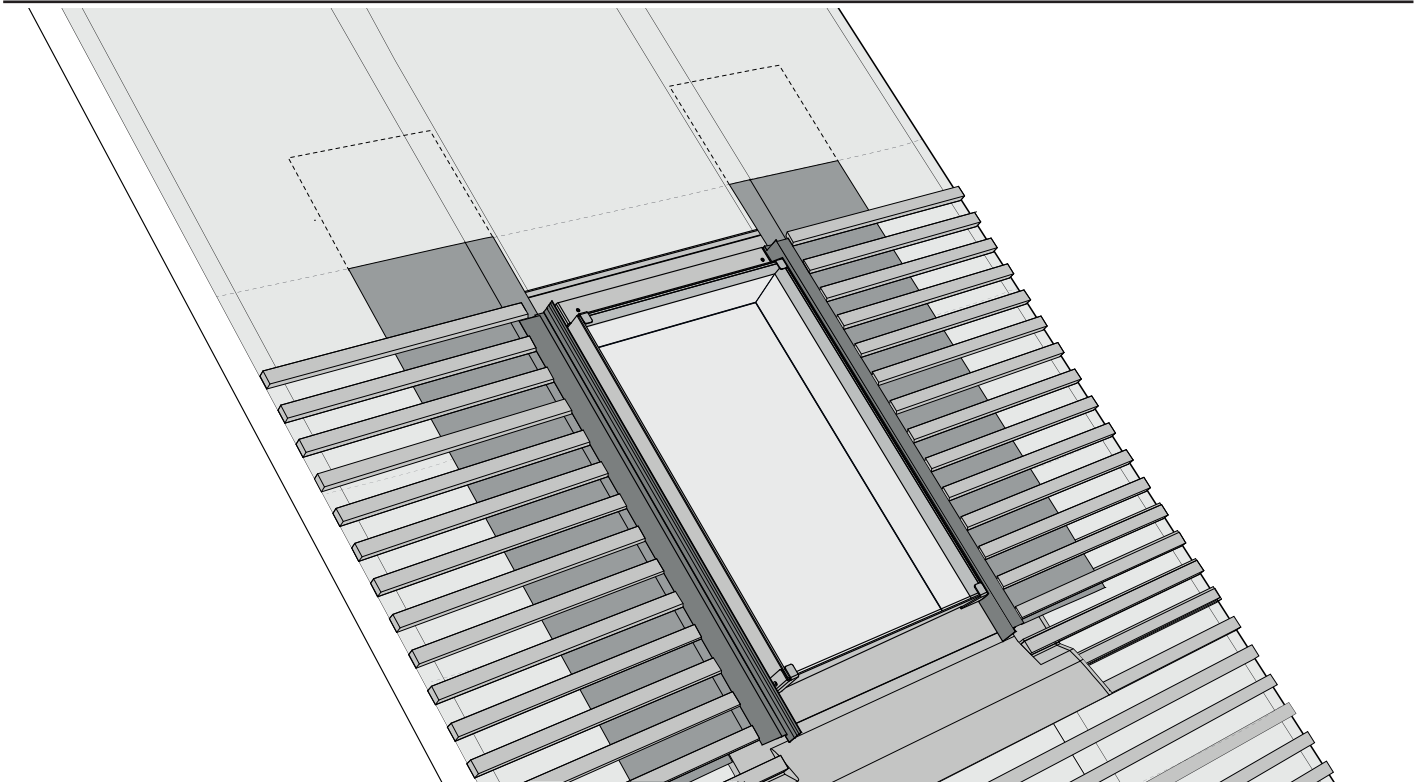

▲ **Battening up the jambs**
Install the battens up the jambs

Install the head tilting fillet as shown (we recommend hardwood or treated softwood). Fix the head tilting fillet to the rafters.

▼ **Installing the head tilting fillet**

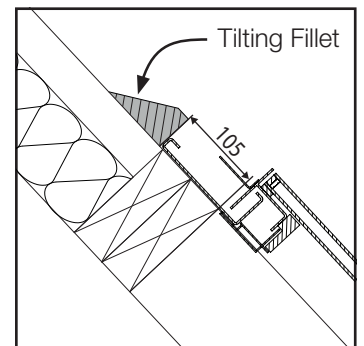
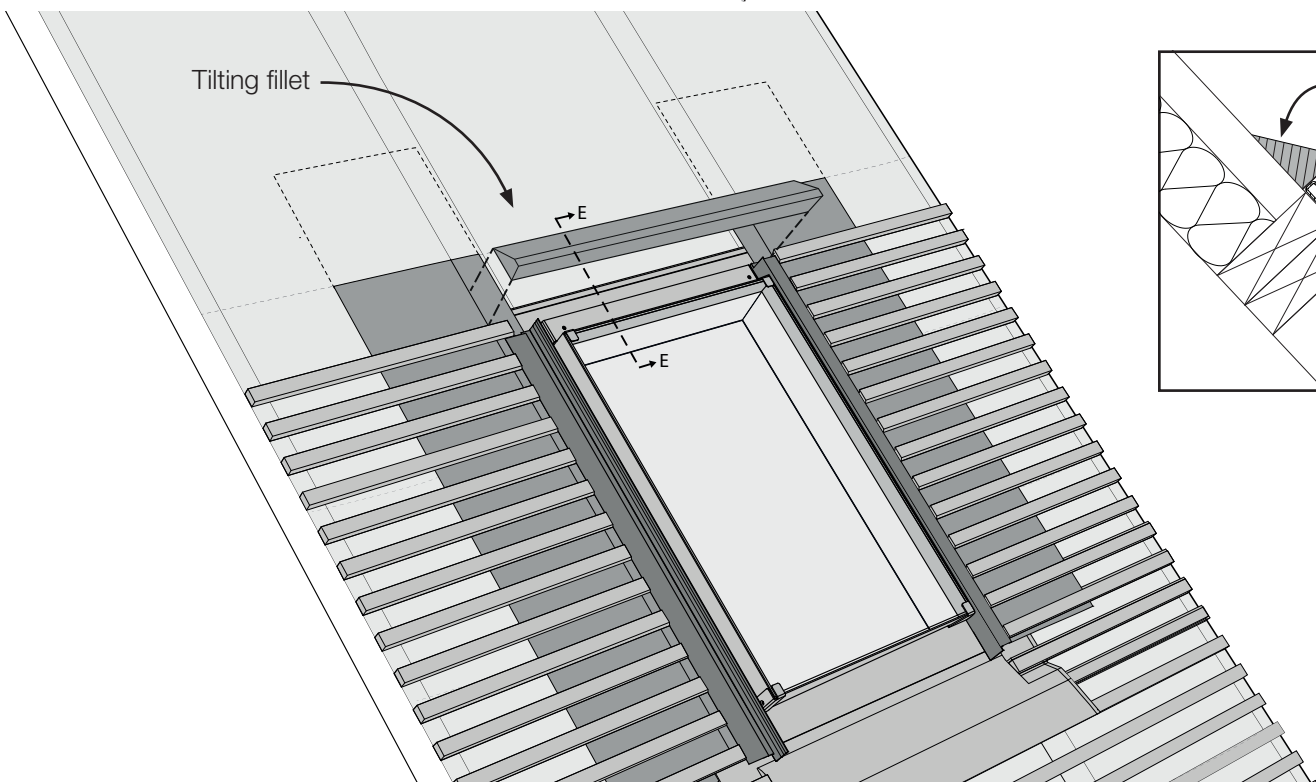

Section E-E

SECTION 6 - Installing the roof window

- > Installing the head lead replacement flashing
- > Installing the head roofing felt



NOTE: If this meets the next lap of the general roofing membrane, ensure it is tucked under the lap as shown.



Lead replacement flashing

▲ Installing the head lead replacement flashing

Lay the head lead replacement flashing (Part 9) over the head fillet. Fold, boss and tuck the flashing back into the baseplate rolover. There may be a requirement to trim the head flashing around the jamb battens depending on their position. This can be done with a sharp stanley knife.

Install the head roofing felt (Part 10). Lay the strip of roofing felt over the lead replacement flashing at the head (Part 9) and ensure it tucks under the next lap in the general roofing membrane.

▼ Installing the head roofing felt

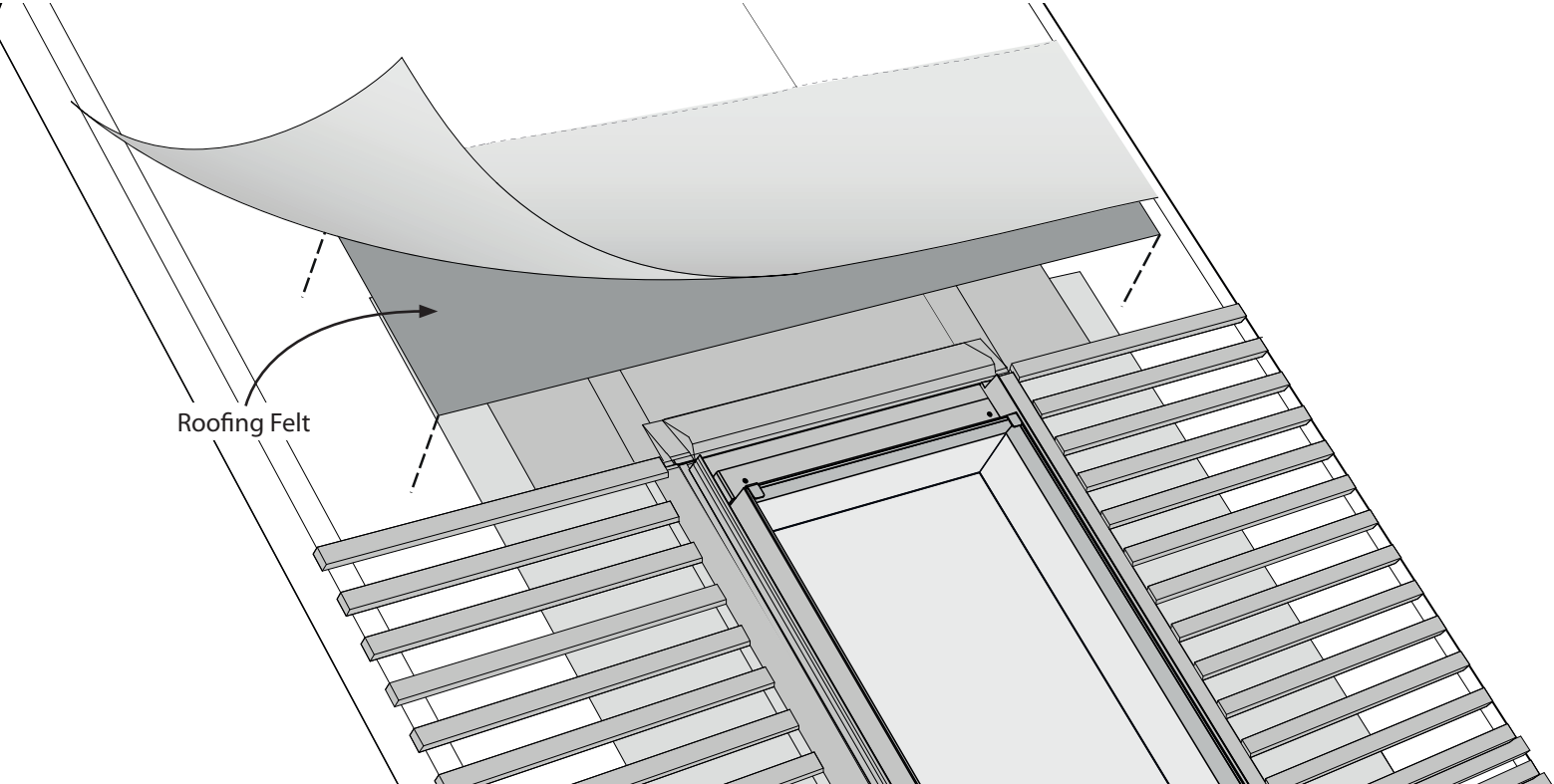

Roofing Felt

SECTION 6 - Installing the roof window

> Weathering

> Installing the battens at the head

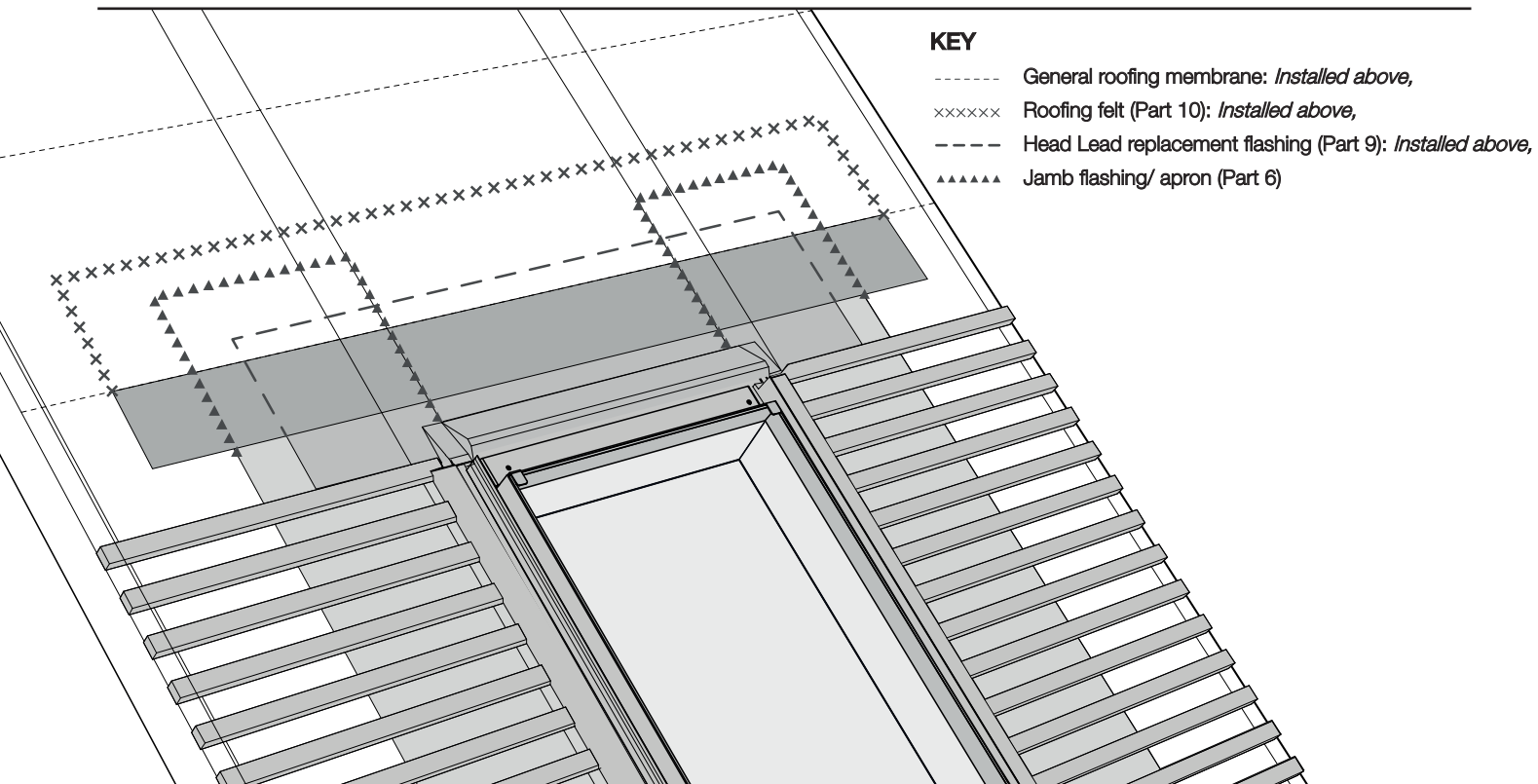

KEY

- General roofing membrane: *Installed above,*
- xxxxxx Roofing felt (Part 10): *Installed above,*
- - - - Head Lead replacement flashing (Part 9): *Installed above,*
- ▲▲▲▲ Jamb flashing/ apron (Part 6)

▲ Weathering

The combination of the lead replacement flashing (Part 9) and the roofing felt (Part 10) being lapped in this way, ensure moisture will run over the tilting fillet onto the baseplate and finally down off the roof.

Finish installing the final rows of battens at the head.

▼ Installing the battens at the head

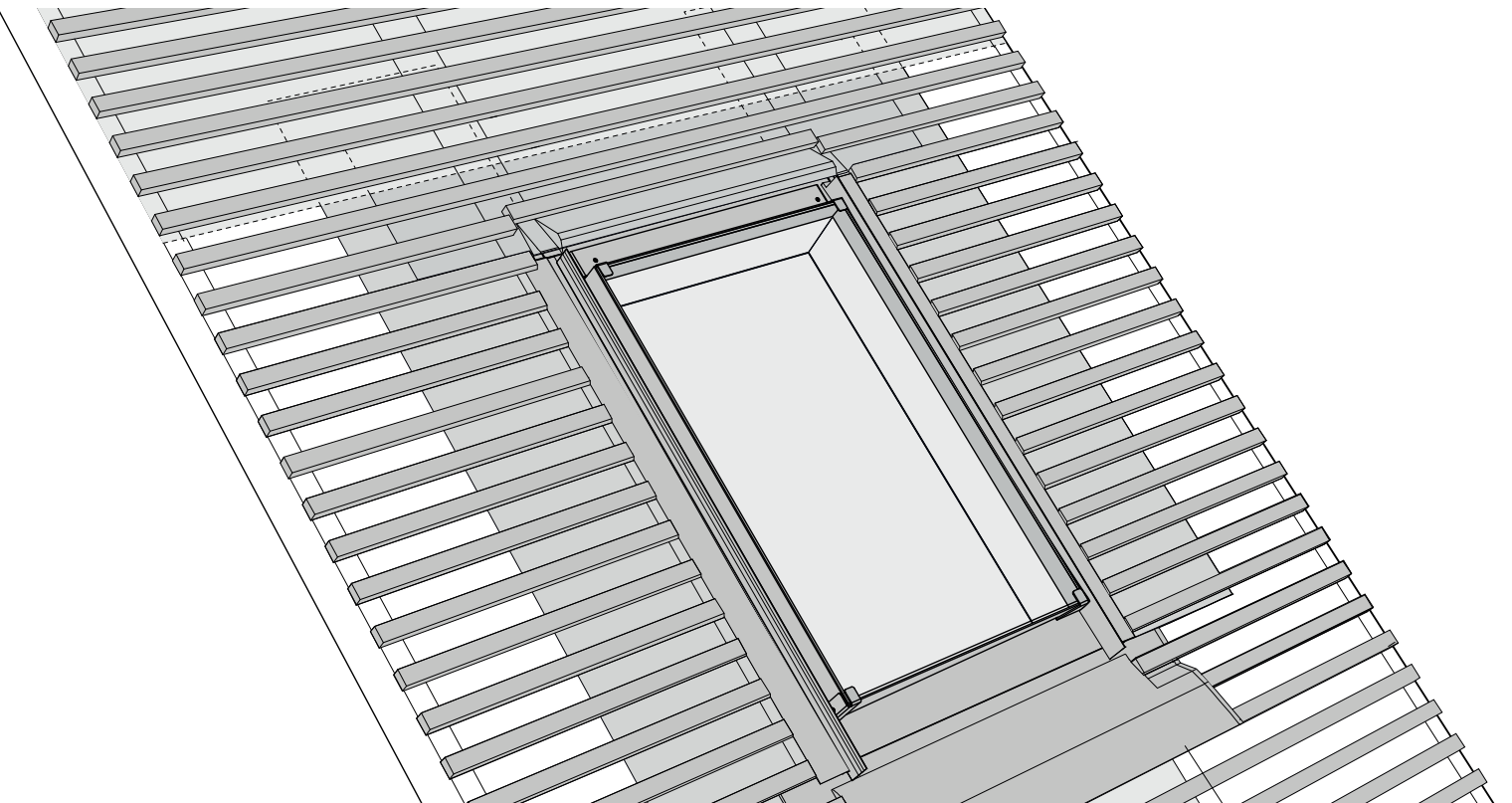

SECTION 6 - Installing the roof window

> Soakers

> Tile up the jambs

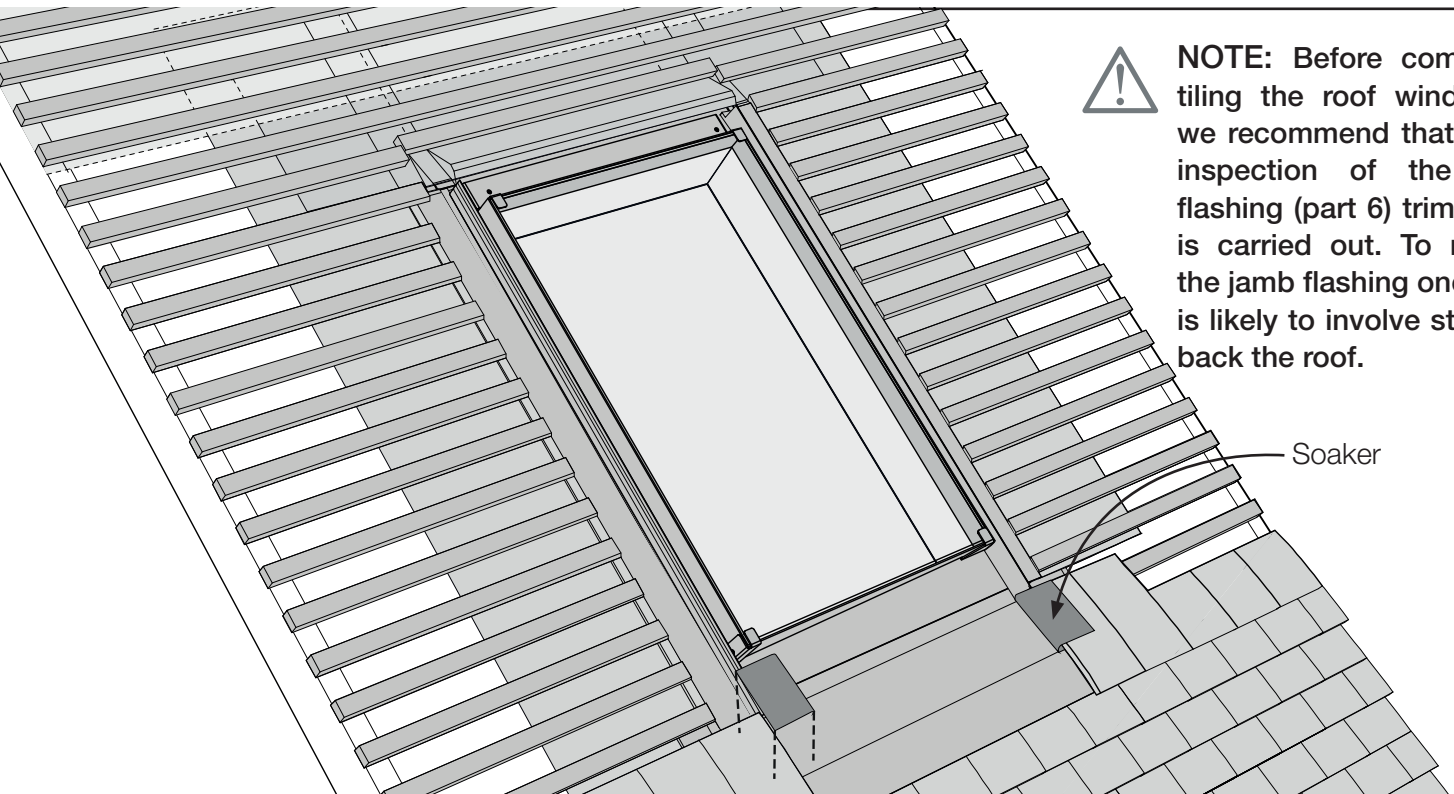

NOTE: Before completely tiling the roof window in, we recommend that a final inspection of the jamb flashing (part 6) trim height is carried out. To replace the jamb flashing once tiled is likely to involve stripping back the roof.

▲ Soakers

Tile up to the cill. Soakers (Part 7) are then required, one per jamb. Lay the soaker flashing over the edge of the cill corner and form the soaker ensuring it tucks behind the jamb flashing extrusion (Part 6) as shown.

Tile the jambs using the edge of the jamb flashing (Part 6) as a guide. Ensure the weathering foam attached to the jamb flashing is folded down and away from the roof window when laying the tiles.

▼ Tile up the jambs

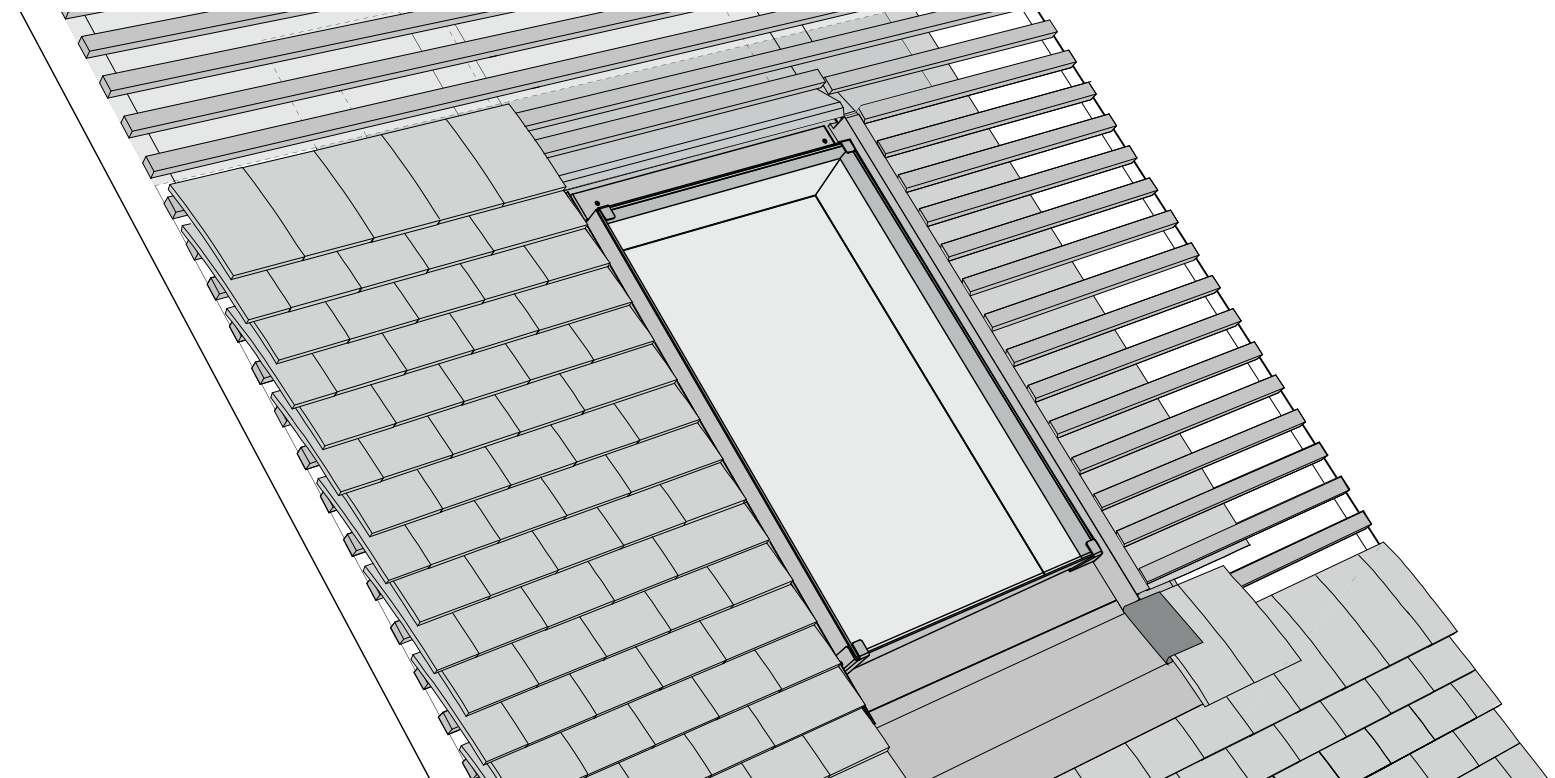

SECTION 6- Installing the roof window

- > Tile the head
- > Complete the tiling



▲ Tile the head

The head of the roof window can now be tiled. We recommend the use of eaves tiles.

Complete the tiling around the head of the roof window accordingly.

▼ Complete the tiling

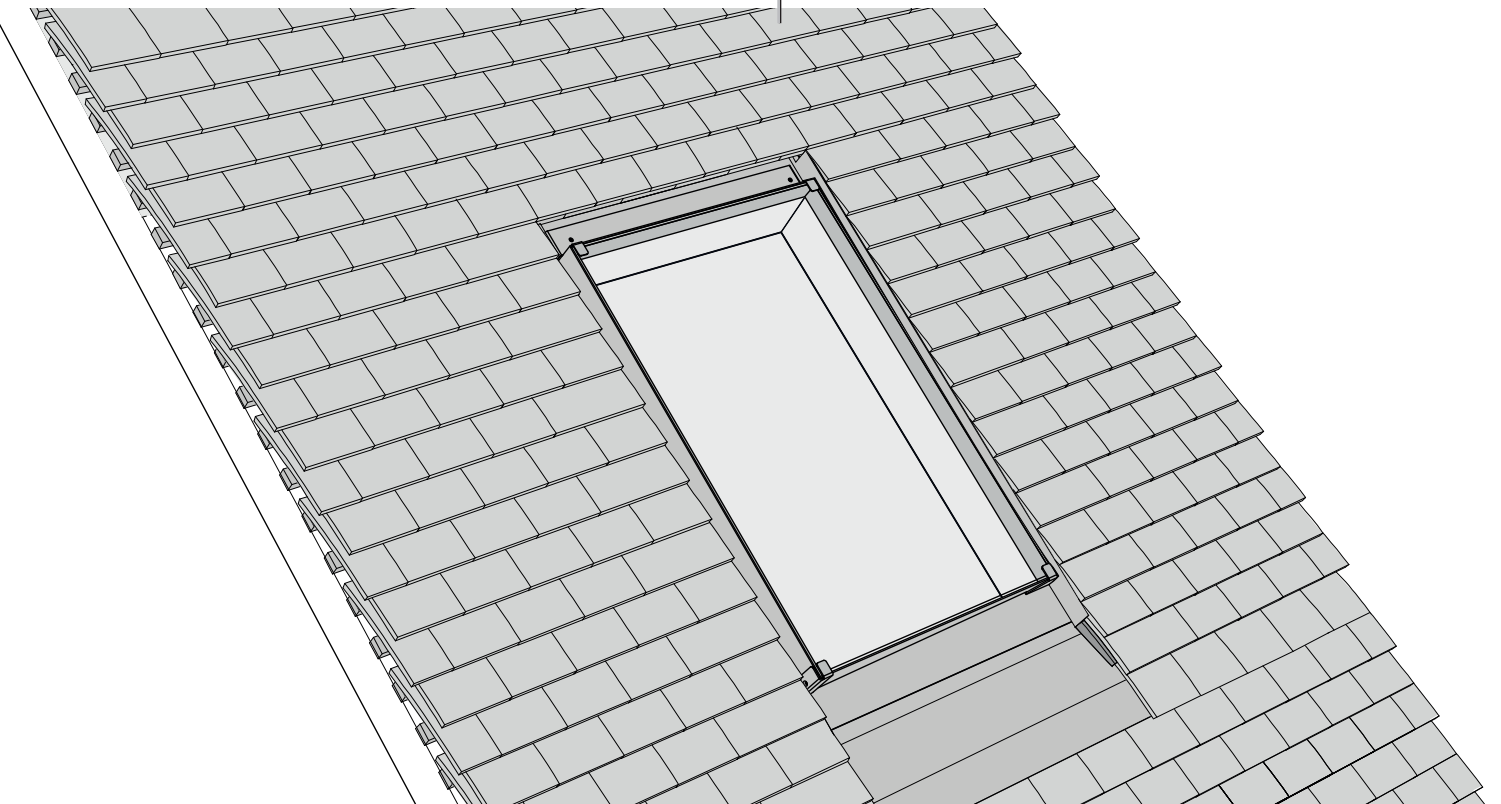

SECTION 7 - Finishing the interior

> Insulation

> Packers

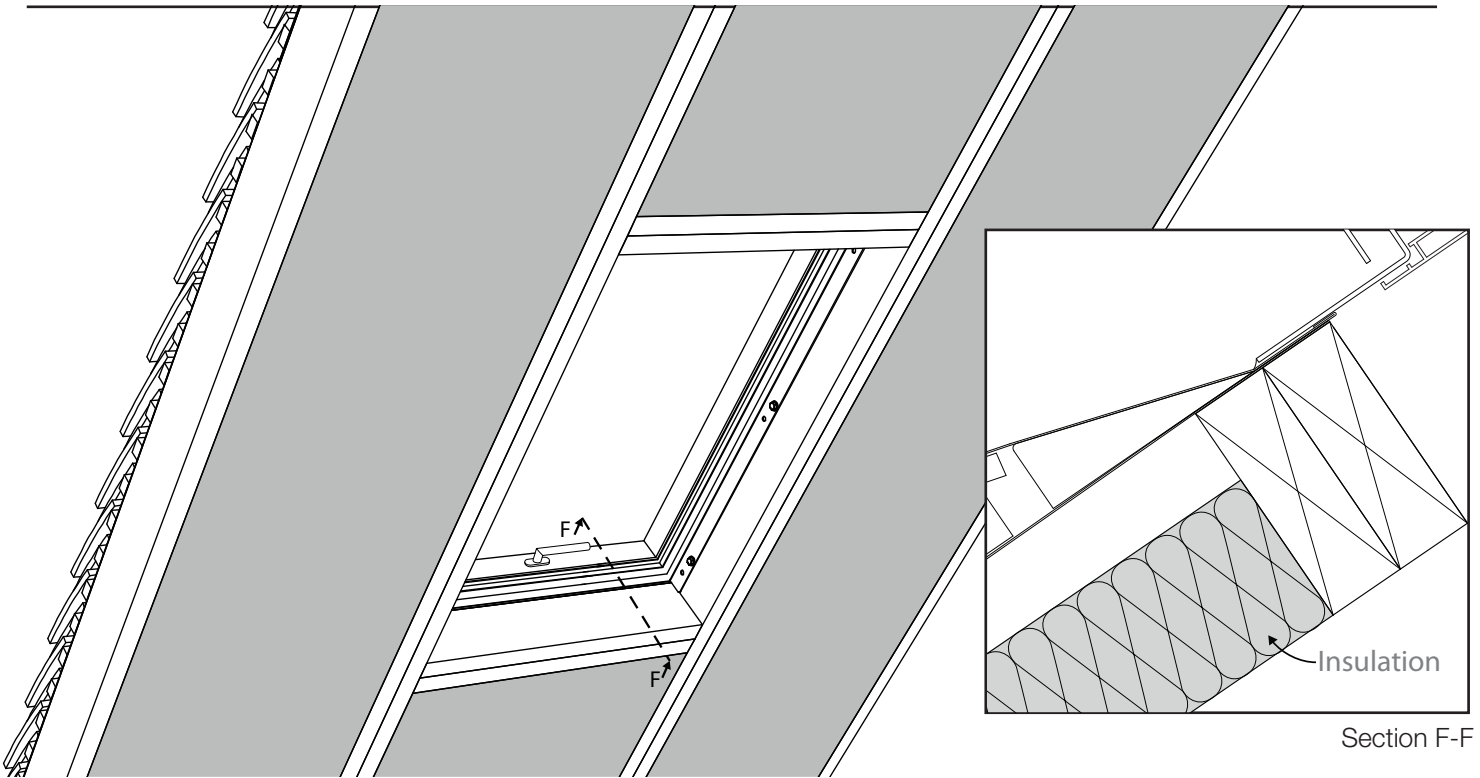

▲ Insulation

Install the insulation between the rafters.

Securely fix timber packers at the top and base of the roof build up at the head, cill and jambs. Use insulation to pack between the timber. Ensure there is sufficient space for the plasterboard and skim so it creates a flush finish.

NOTE: Ensure there is a timber packer at the cill of the roof window to securely fix the ironmongery.

▼ Packers

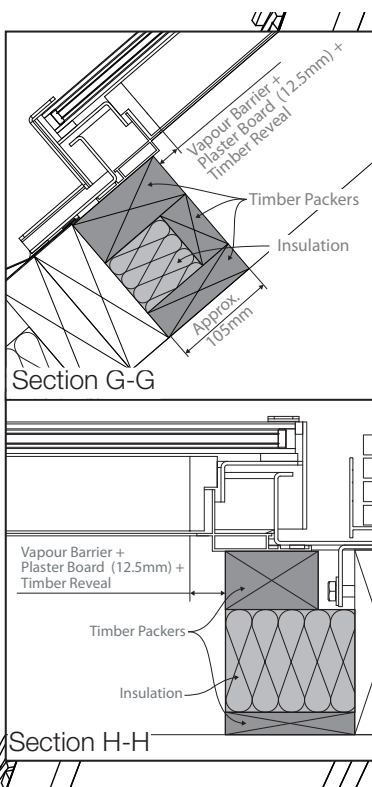

NOTE: If the roof window is motorised there will be a cable running out of the left jamb. This needs to be routed around the packers so it can be connected to the power supply in accordance with the motor installation instructions.

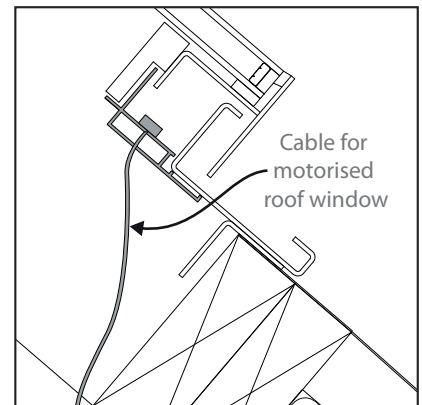

SECTION 7 - Finishing the interior

- > Vapour barrier
- > Plasterboard & Skim

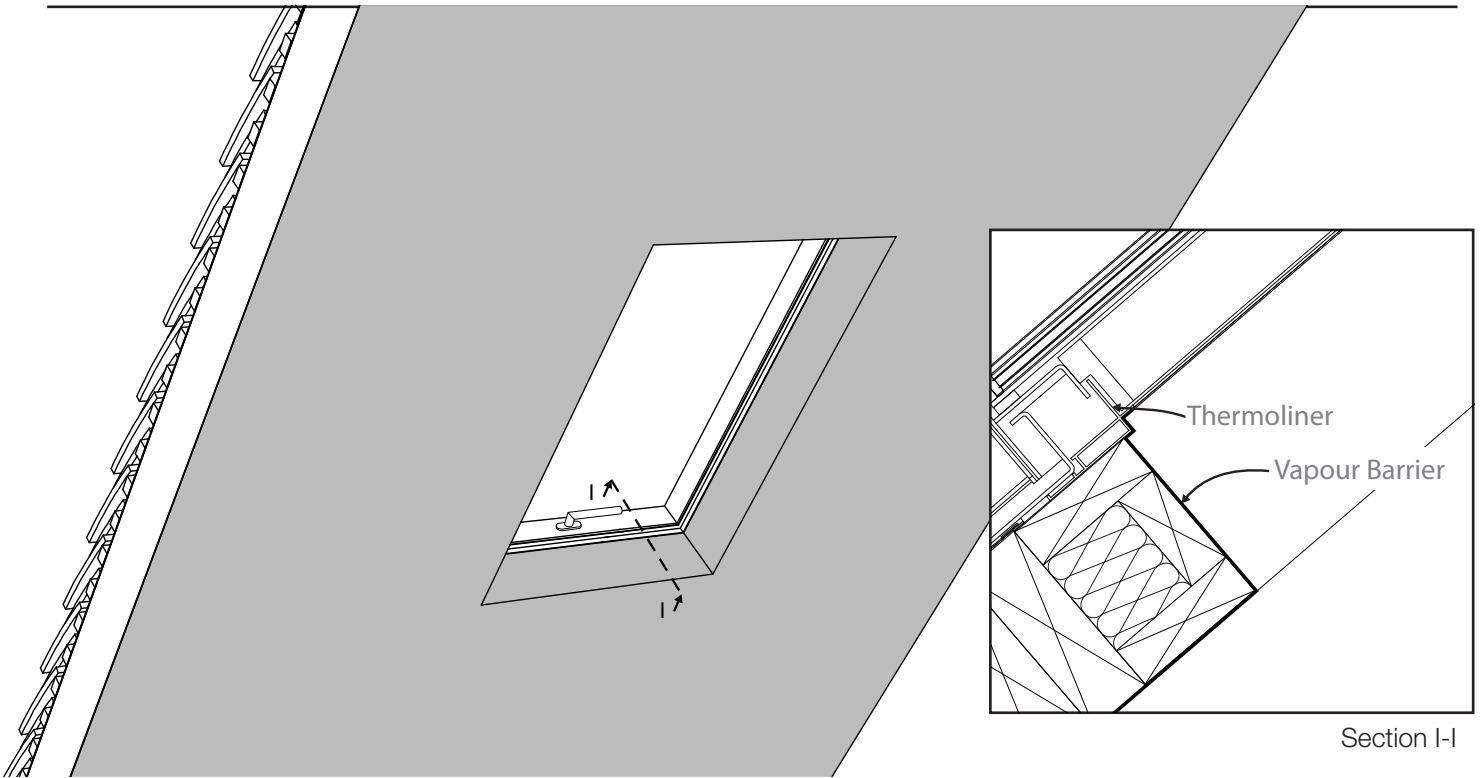

▲ Vapour barrier

Install the vapour barrier around the roof window. This should finish at the thermoliner as shown.

Install the plasterboard over the ceiling. Ensure there is a 12.5mm overlap with a plaster stop on the corner. Then insert the plasterboard around the head, cill and jambs, behind the bottom left of the thermoliner as shown. Skim the main ceiling plasterboard but NOT the head, jambs and cill.

▼ Plasterboard & Skim

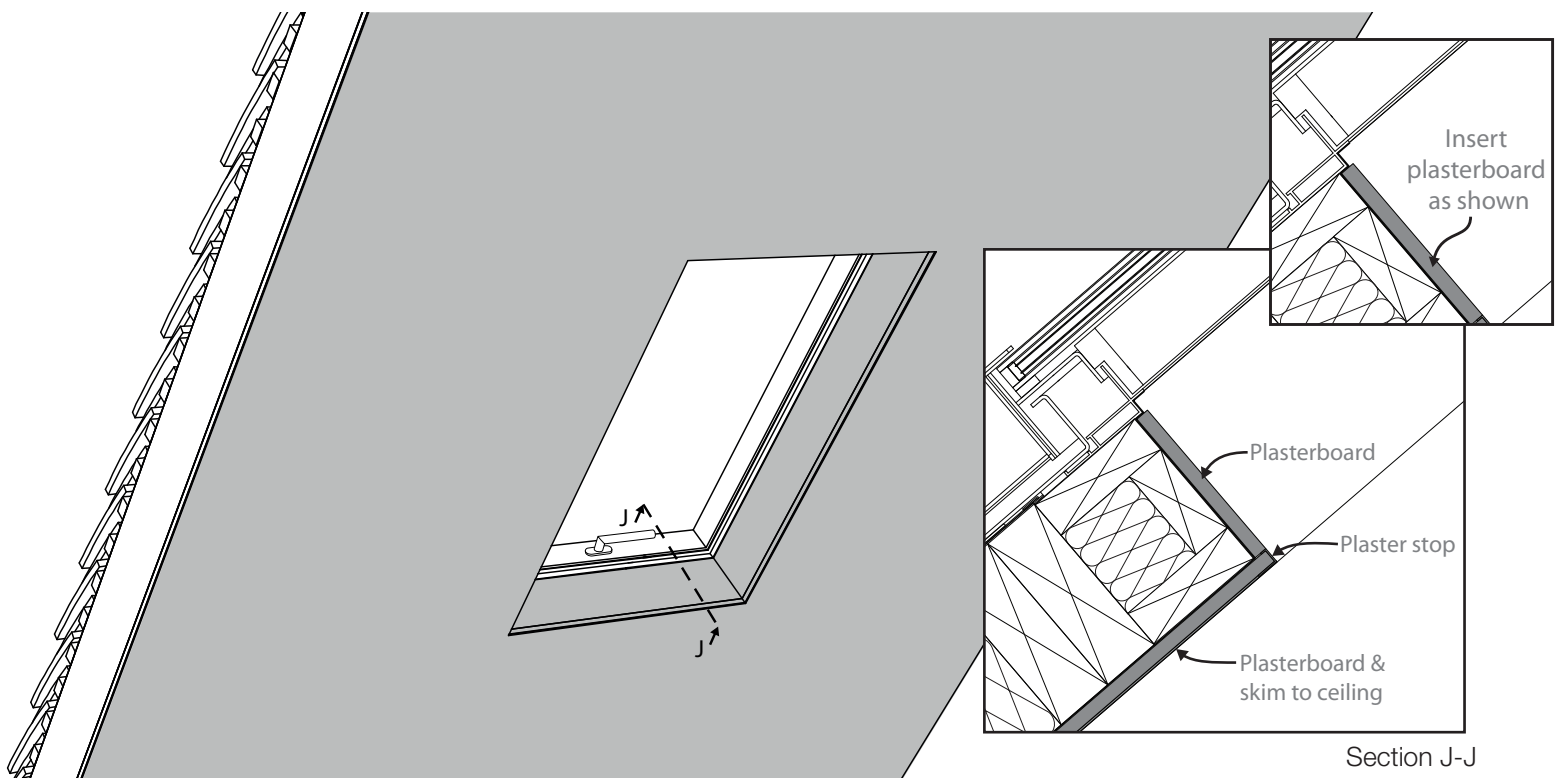

SECTION 7 - Finishing the interior

- > Timber reveal & architrave
- > Paint the timber lining

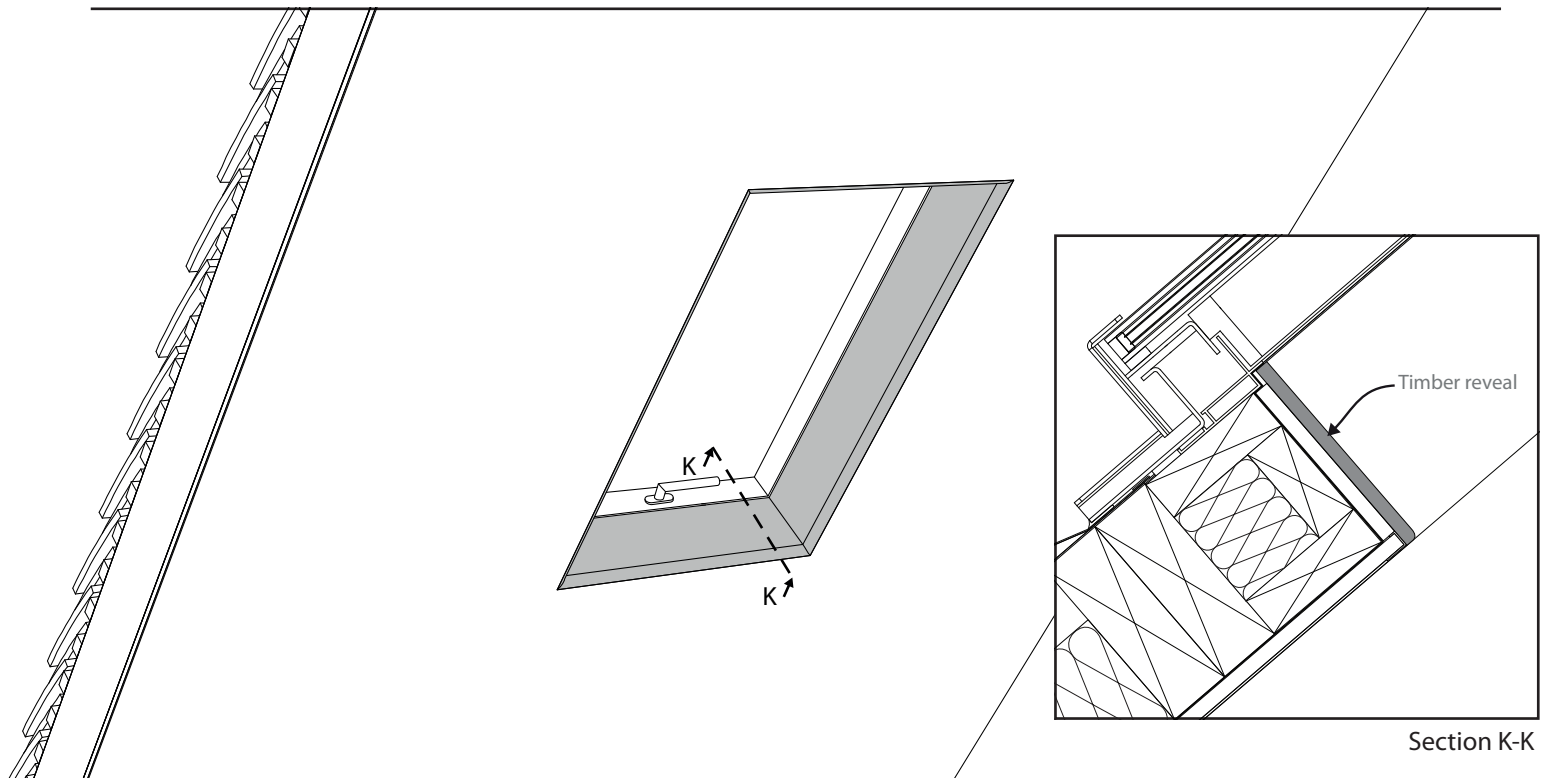

▲ Timber reveal & architrave

To complete the installation and provide a frameless internal appearance, fit a timber reveal around the head, cill and jambs, over the plasterboard. Ensure there is no interference with the thermoliner.

For roof windows without a factory painted timber lining- this step must be completed to ensure longevity of this component. Paint the unfinished timber lining with a timber finishing paint. Ensure all four sides are painted.

▼ Paint the timber lining

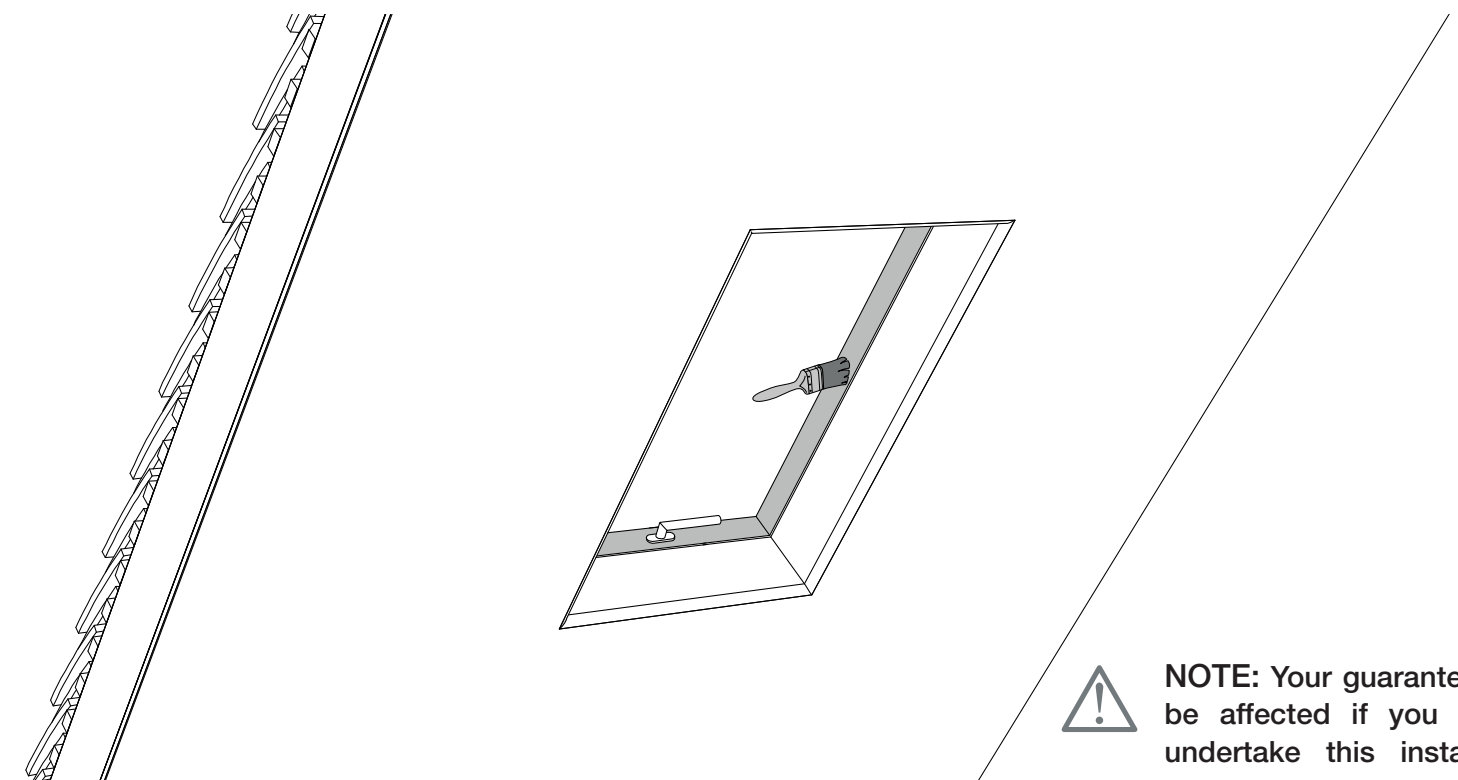

NOTE: Your guarantee may be affected if you fail to undertake this installation

SECTION 7 - Finishing the interior

> Completion of installation

SECTION 8- Suggested installation details

> Drawing identification

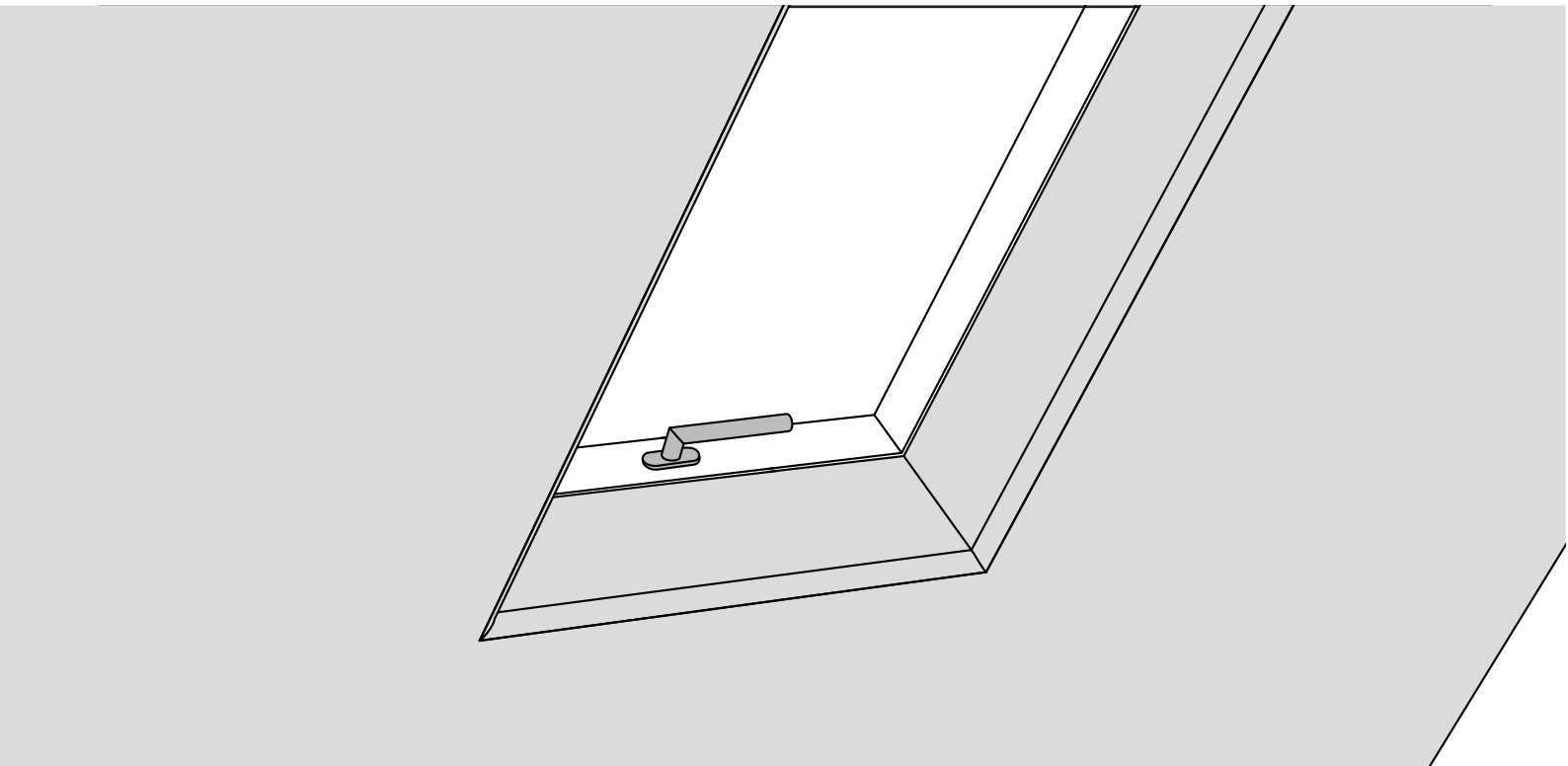

▲ Completion of installation

This completes the installation of the roof window frame. To service the ironmongery, please refer to the separate maintenance manual.

DRAWING IDENTIFICATION

CLAY TILE ROOF FINISH (On the rafters)

Page

Cold roof construction	drawing number - SN_CRCS_FK_C	26
Warm roof construction	drawing number - SN_WRCS_FK_C	27



For additional installation details, please visit our website or contact the commercial services team.

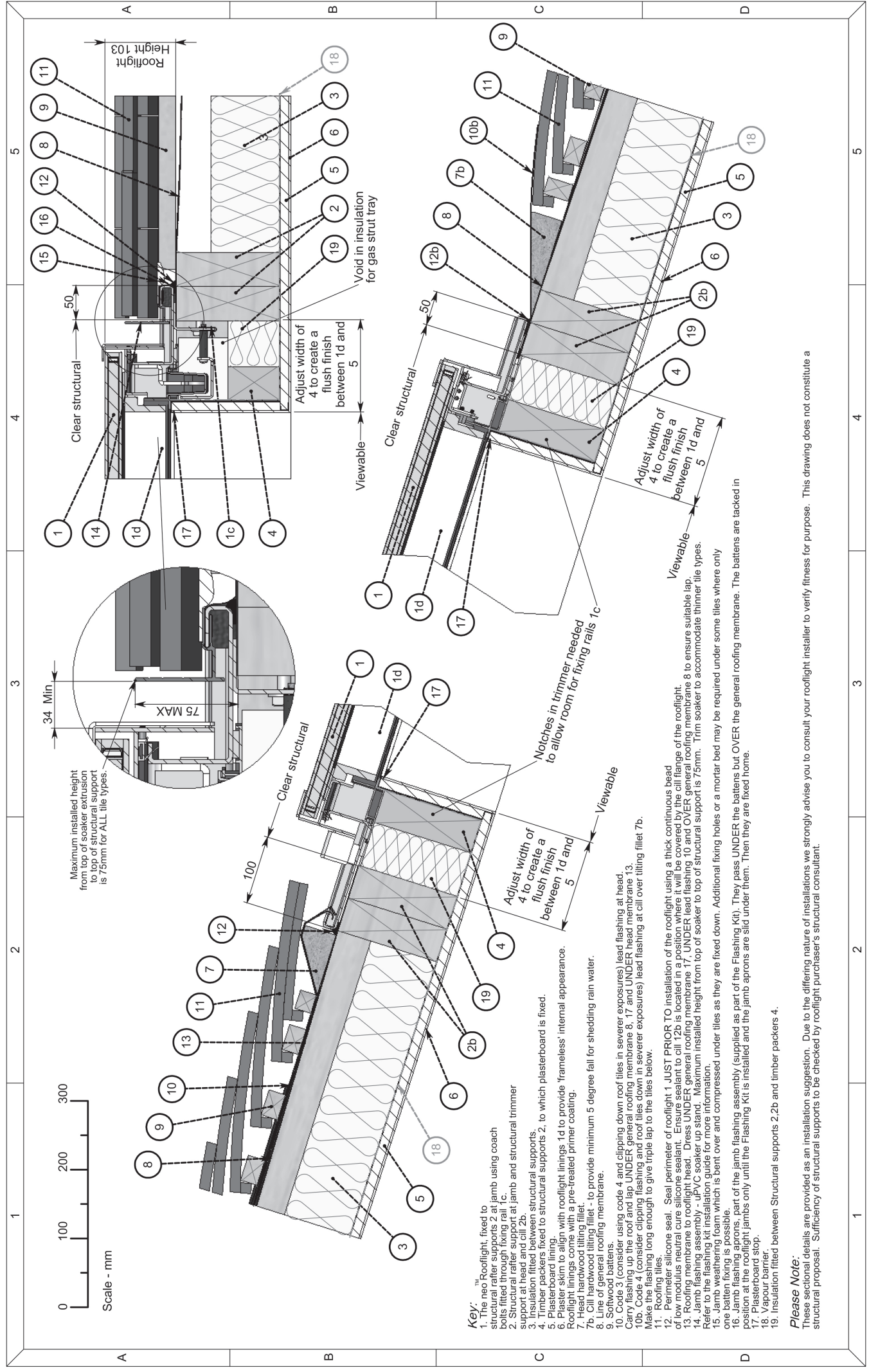

- Key:**
1. The Neo Rooflight, fixed to structural rafter supports 2 at jamb using coach bolts fitted through fixing rail 1c.
 2. Structural rafter support at jamb and structural trimmer support at head and cill 2b.
 3. Insulation fitted between structural supports.
 4. Timber packers fixed to structural supports 2, to which plasterboard is fixed.
 5. Plasterboard lining.
 6. Plaster skim to align with rooflight linings 1d to provide 'frameless' internal appearance.
 7. Rooflight linings come with a pre-treated primer coating.
 - 7b. Cill hardwood tilting fillet - to provide minimum 5 degree fall for shedding rain water.
 8. Line of general roofing membrane.
 9. Softwood battens.
 10. Code 3 (consider using code 4 and slipping down roof tiles in sewerer exposures) lead flashing at head.
 11. Carry flashing up the roof and lap UNDER general roofing membrane 8, 17 and UNDER head membrane 13.
 12. Make the flashing long enough to give triple lap to the tiles below.
 11. Roofing tiles.
 12. Perimeter silicone seal. Seal perimeter of rooflight 1 JUST PRIOR to installation of the rooflight using a thick continuous bead of low modulus neutral cure silicone sealant. Ensure sealant to cill 12b is located in a position where it will be covered by the cill flange of the rooflight.
 13. Roofing membrane to rooflight head. Dress UNDER general roofing membrane 17, UNDER lead flashing, 10 and OVER general roofing membrane 8 to ensure suitable lap.
 14. Jamb flashing assembly - uPVC soaker up stand. Maximum installed height from top of soaker to top of structural support is 75mm. Trim soaker to accommodate thinner tile types. Refer to the flashing kit installation guide for more information.
 15. Jamb weathering foam which is bent over and compressed under tiles as they are fixed down. Additional fixing holes or a mortar bed may be required under some tiles where only one batten fixing is possible.
 16. Jamb flashing aprons, part of the jamb flashing assembly (supplied as part of the Flashing Kit). They pass UNDER the battens but OVER the general roofing membrane. The battens are tacked in position at the rooflight; jamba only until the Flashing Kit is installed and the jamb aprons are slid under them. Then they are fixed home.
 17. Plasterboard stop.
 18. Vapour barrier.
 19. Insulation fitted between Structural supports 2,2b and timber packers 4.

Please Note: These sectional details are provided as an installation suggestion. Due to the differing nature of installations we strongly advise you to consult your rooflight installer to verify fitness for purpose. This drawing does not constitute a structural proposal. Sufficiency of structural supports to be checked by rooflight purchaser's structural consultant.

TITLE: Neo Rooflight®

> A roof window range suitable for pitched roofs between 20° and 60°

Cold Roof | Clay Tile | Flashing Kit | On the rafter' installation detail

DWG NO.: SN_CRCS_FK_E

SCALE: 1:5 @ A3

SHEET NO.: 1 OF 1

DATE: 19/07/2023

REVISION: E

Updates to Formating

DB:EH CR:PD

THE ROOFLIGHT CO. COTTSWOLDS

www.therooflightco.com t: 01993 833 108 e: hello@therooflightco.com

The Rooflight Co is a trading name of The Metal Window Company Limited - Company No. 2881879. All information contained in this drawing is copyright of The Metal Window Company Limited. The intellectual property rights of the products detailed within this drawing and embedded 3D models are owned by The Metal Window Company Limited.

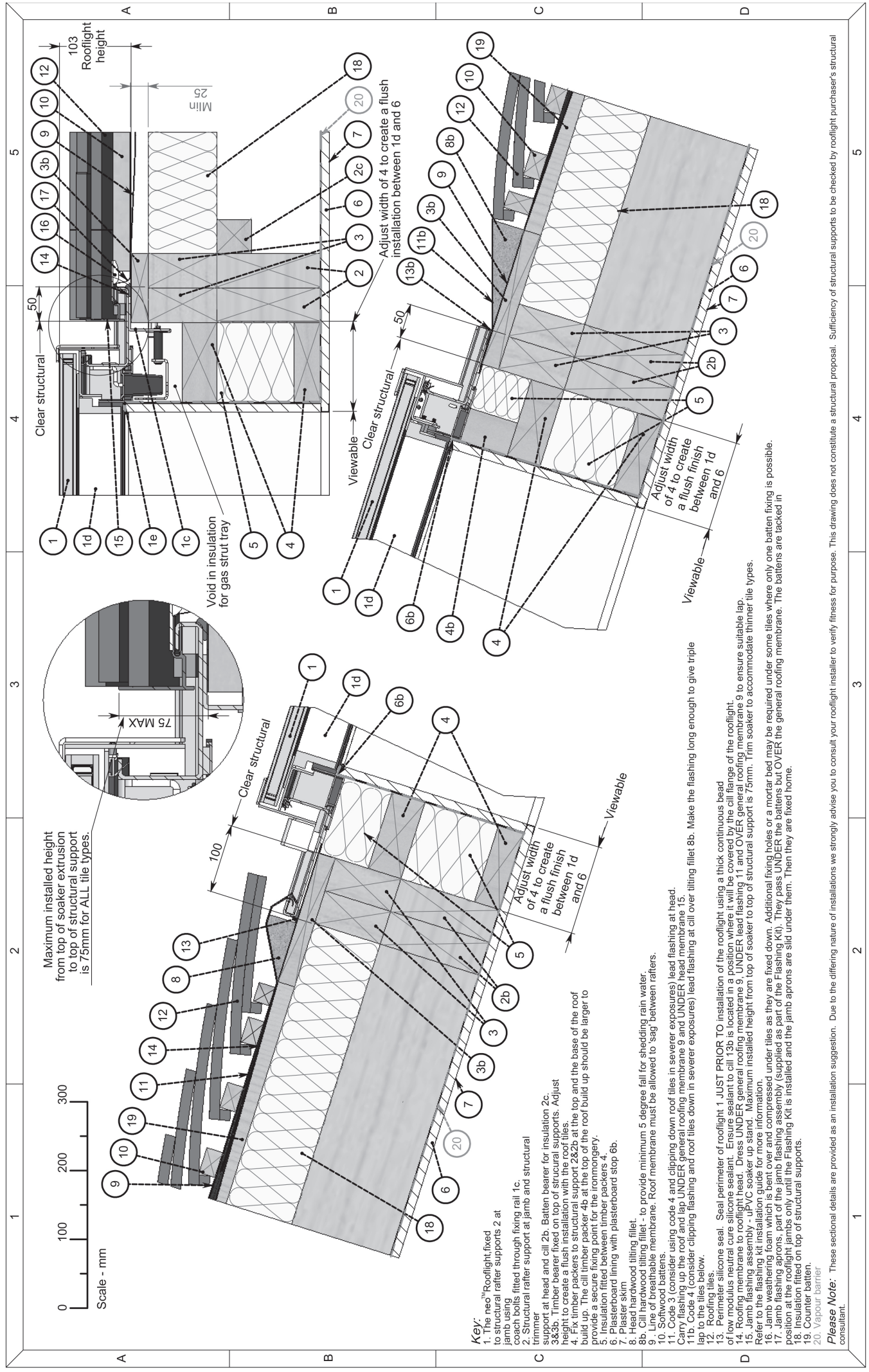

SECTION 9 - Important Information

- > Care & maintenance
 - > Conformity
 - > Advisory
-

CARE & MAINTENANCE



To achieve the maximum service life from the Neo® Rooflight it is important that scheduled care and maintenance is undertaken. Please note: Refer to separate **TECHNICAL SPECIFICATION AND MAINTENANCE DETAILS FOR METAL FRAMED ROOF WINDOWS**

CONFORMITY



Effective 1 January 2021, we have transitioned to the UKCA/ UKNI markings as per UK legislative requirements. This replaces CE marking which is no longer recognised by EU members for UK manufactured products. Please note this is of critical importance for customers planning to export our products to EU27 countries, who are responsible for ensuring compliance with relevant local export rules.



ADVISORY



Standard roof window: All the information provided in this document refers to a standard specification Neo® Rooflight.



Install in accordance with national building regulations/codes. This manual is an installation suggestion and installers should verify 'fitness for purpose' in accordance with all applicable regulations/ standards at time of installation.



Install in accordance with this manual: The Rooflight Co cannot accept any liability if the Neo® Rooflight is not installed strictly in accordance with the instructions contained in this manual and implicit in the 'Suggested Installation Details'.



Structural support: Structural supports for the Neo® Rooflight are to be designed and supervised during construction by the roof window installer or project Structural Engineer. Nothing in this manual constitutes a structural proposal. Sizing/positioning of structural supports should be determined by the projects suitably qualified structural engineer.

SECTION 9 - Important Information

> Roof window weight and opening angle

> Further Information

ROOF WINDOW WEIGHTS

When handling and installing the Neo® Rooflight its weight should be considered and adequate means employed to move the roof window into position to reduce the risk of accidents.

MODEL REFERENCE NUMBER	APPROXIMATE CASEMENT WEIGHT (KG)	APPROXIMATE BASEPLATE WEIGHT (KG)	OVERALL ROOF WINDOW WEIGHT (KG)
neo-01	19	16	35
neo-02	24	19	43
neo-03	32	23	55
neo-04	33	23	56
neo-05	43	29	72
neo-06	37	25	62
neo-07	43	28	71
neo-08	59	35	94
neo-09	59	33	92
neo-10	78	40	118
neo-11	45	31	76
neo-12	60	39	99
neo-13	79	45	124
neo-14	33	23	56
neo-15	56	31	87

PRODUCT IDENTIFICATION DETAILS

Place identification sticker here or fill in the following details.

Serial number: _____

Model Number: _____

Date of manufacture: __/__/____

FURTHER INFORMATION

All of the images in this guide are diagrammatic (with some components omitted for clarity). They should be used as a reference and may not be a true representation of the installation.

Installation instructions are regularly reviewed and we reserve the right to update or amend these details without alteration to this guide.

July 2024

NOTES

Installation Manual

Neo[®] Rooflight

Please register your product at: www.therooflightco.com

Unit T1, Bourton Industrial Park
Bourton-on-the-Water
Gloucestershire
GL54 2HQ

THE
ROOFLIGHT CO.
COTSWOLDS

T: 01993 833155

E: hello@therooflightco.com

www.therooflightco.com



In the interest of continuous product development, it may be necessary to amend specification without alteration to technical literature.

All drawings and designs are the Copyright and Design right of The Metal Window Company Ltd.